

Performance

- Frequency: 9.5-10.5GHz
- Gain: 8dB
- Output Power: 52dBm (Typ.)
- PAE: 35% (Typ.)
- Bias: 28V/-3.0V
- Hermetically Sealed Package
- Size: 24.0*17.4*4.4mm



Electrical Specifications (Ta=+25°C, 50Ω system)

Symbol	Parameter	Test Condition	Min	Typical	Max	Unit
P _{out}	Output Power	V _d =28V, V _g =-3.0V Freq: 9.5-10.5GHz 100us, 10% D.C		52	-	dBm
G _p	Power Gain		-	8	-	dB
η _{add}	Power Added Efficiency		-	35	-	%
ΔG _p	Gain Flatness		-0.8	-	+0.8	dB

Test Curves (Ta=+25°C)

Output Power and PAE

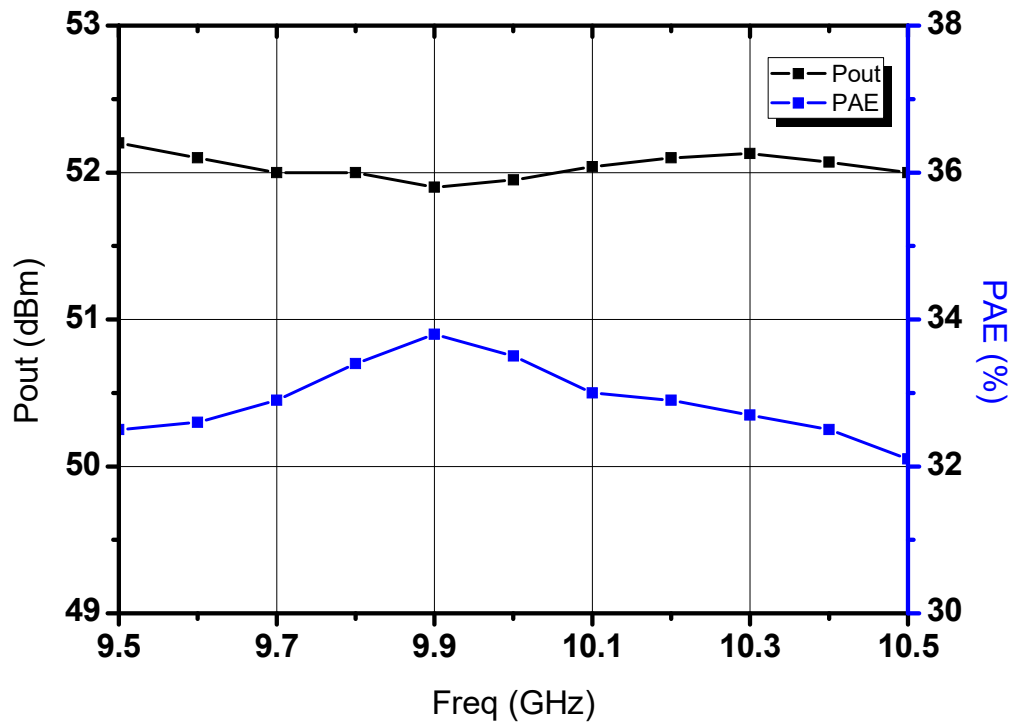

Absolute Max Ratings (TA=25°C)

Symbol	Parameter	Value	Remark
Vds	Drain Bias Voltage	40V	
Vgs	Gate Bias Voltage	-5V	
Pd	DC Power Consumption	125W	25°C
Tch	Channel Temperature	225°C	
Tm	Sintering Temperature	300°C	1min, N2 protection
Tstg	Storage Temperature	-55~175°C	

Exceeding any one or combination of these limits may cause permanent damage.

Outline Size

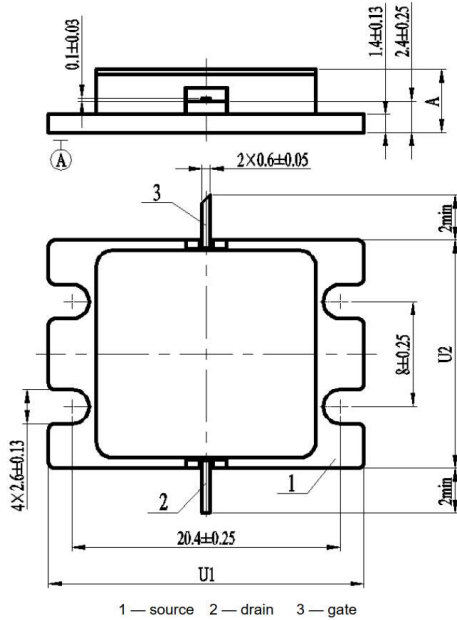

Symbol	Min	Max
U1	23.8	24.2
U2	17.2	17.6
A		5.2