

Performance

- Dual paths output: $F_0=23.8\sim 25.0\text{GHz}$
 $F_0/16=1.4875\sim 1.5625\text{GHz}$
- Output Power: +9dBm
- Noise figure: -92dBc/Hz @ 100KHz Typ
- Chip size: 1.67*1.77*0.1mm

Function Diagram

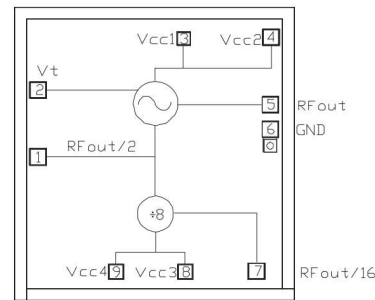

Electrical Specifications (Ta=+25°C, Vcc=+5V)

Parameter		Min	Typical	Max	Unit
Frequency Range	F0	23.8~25.0			GHz
	F0/16	1.4875~1.562510			GHz
Output Power	RFOUT	9	10	11	dBm
	RFOUT/16	-7	-5	-3	dBm
Noise figure@100KHz, VTUNE=+5V@RFOUT		-	-92	-	dBc/Hz
Tuning Voltage		2	-	13	V
Harmonics	1/2	-	-15	-	dBc
	2 nd	-	-20	-	dBc
Frequency Pulling (12dB RL)		-	15	-	MHz
Pushing Frequency Factor @ VTUNE=5V		-	85	-	MHz/V
Frequency Shift		-	2.8	-	MHz/°C
Operating Current		190	210	230	mA

Test Curves (Die chip test)

Output Freq vs. Tuning Voltage, TA=+25°C

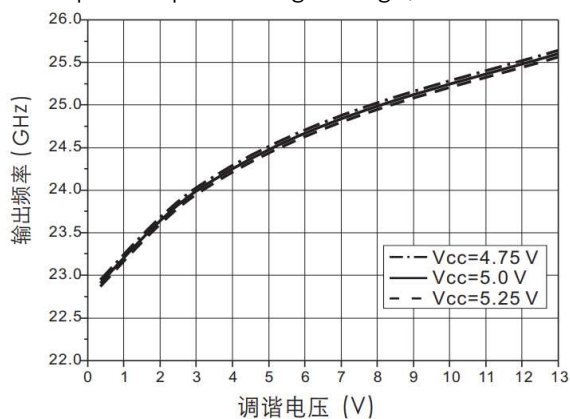

Output Freq vs. Tuning Voltage, Vcc=+5V

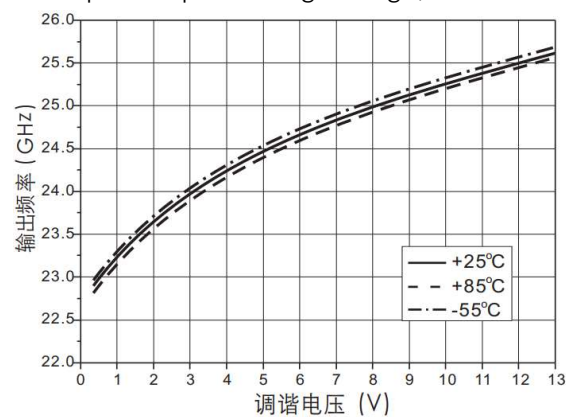

Electronic tuning sensitivity vs. Tuning Voltage
Vcc=+5V

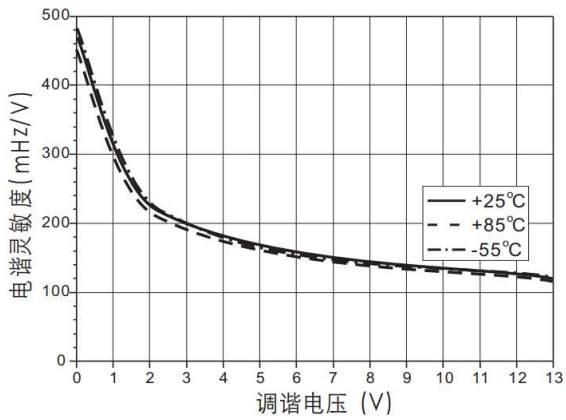

Output Power vs. Tuning Voltage, Vcc=+5V

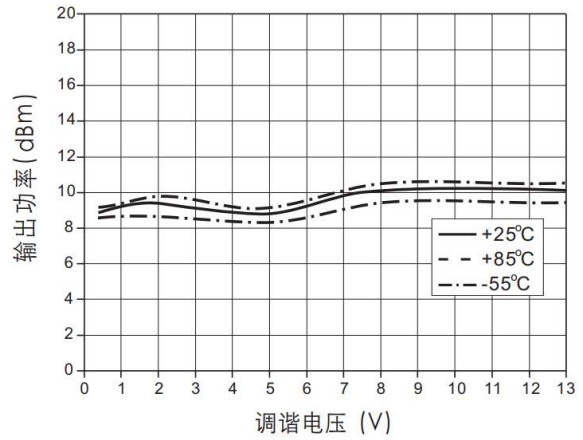

SSB Noise Figure vs. Tuning Voltage

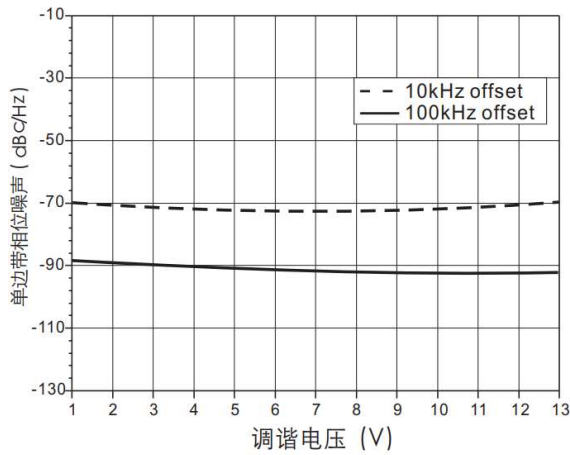

SSB Noise Figure vs. Vtune=+5V

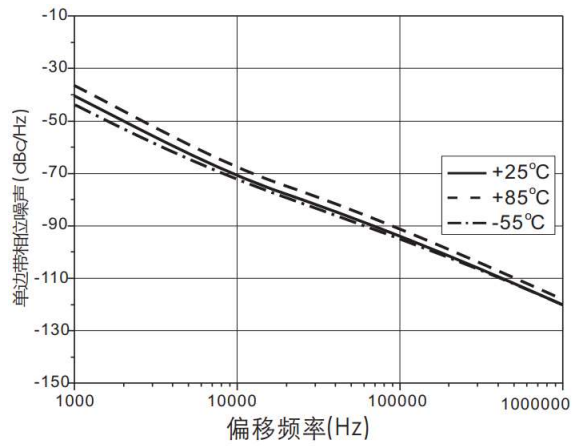

RFOUT/2 Frequency vs. Tuning Voltage
Vcc=+5V

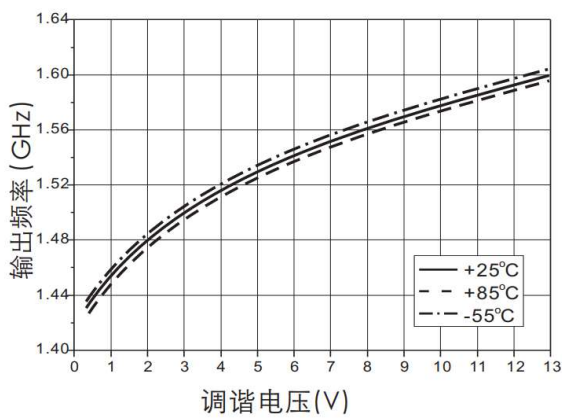

RFOUT/2 Output Power vs. Tuning Voltage
Vcc=+5V

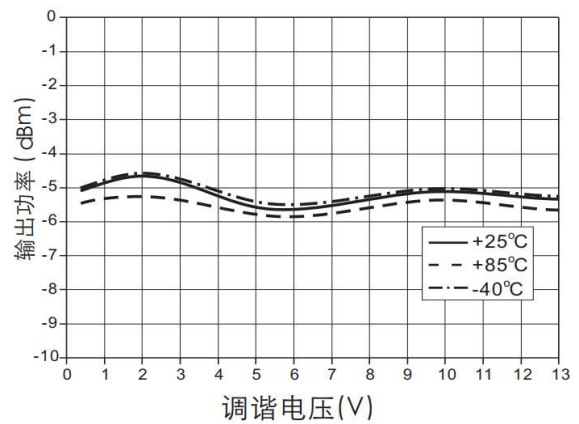

Absolute Ratings

Vcc	+5.5Vdc
Vtune	0~+15V
Junction Temperature	175°C
Storage Temperature	-65°C~+150°C
Operating Temperature	-55°C~+125°C
Static Protection	Class 1A

Typical Operating Current

Vcc(V)	ICC(mA)
4.75	190
5.0	210
5.25	230



ELECTROSTATIC SENSITIVE DEVICE
OBSERVE HANDLING PRECAUTIONS

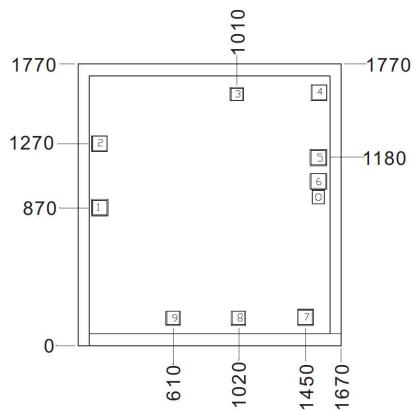

Outline Size



Note:

1. Unit: um
2. Bottom side is gold plated
3. Bottom side is GND
4. Bonding pads is gold plated, Pad size: 100*100(um)
5. Don't bonding on thru holds
6. Tolerance: ±50um

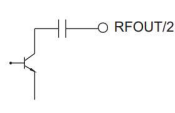
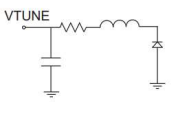
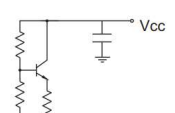
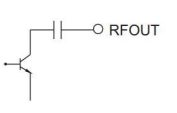
Bonding Pads Definition

Number	1	2	3,5	4	
Symbol	RFOUT/2	VTUNE	Vcc	RF OUT	GND
Description	1/2 harmonic output (block capacitor included)	Tuning Voltage port	Current port, +5V	RF output port (block capacitor included)	Bottom must be grounded
Equivalent Circuit					

Assembly Drawing

