

Performance

- Frequency: 6~18GHz
- Insertion loss: 1.0dB
- Chip size: 2.20*1.30*0.1mm

Function Diagram

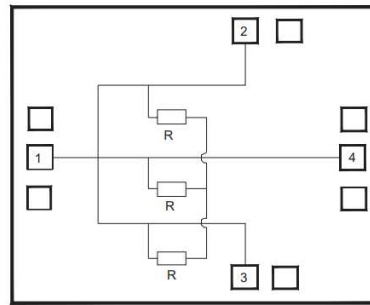

Electrical Specifications (Ta=+25°C, 50Ω system)

Parameter	Min	Typical	Max	Unit
Frequency Range		6~18		GHz
Insertion Loss	-	1.0	1.5	dB
Insertion Loss Ripple	-	±0.3	-	dB
Isolation	15	20	20	dB
Input Return Loss	11	15	-	dB
Output Return Loss	15	20	-	dB

Test Curves

