

Performance

- Frequency: 2~6.5GHz
- Typical Signal Gain: 28dB
- Typical Pout: 37dBm@28V
- Typical PAE: 40%
- Bias: 28V, -2.0V (Typ.)
- Mode: CW
- Technology: 0.25um HEMT
- Size: 1.4mm*2.15mm*0.08mm

Function Diagram

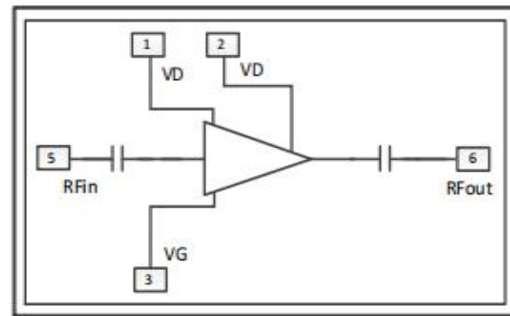

Electrical Specifications (TA=25°C, Vd=28V, Idq=0.24A, F: 2~6.6GHz, CW)

| Symbol | Parameter | Min | Typical | Max | Unit |
|--------|------------------------|-----|---------|-----|------|
| G | Small Signal Gain | - | 28 | - | dB |
| Gp | Power Gain | - | 17 | - | dB |
| Pout | Saturated Power | - | 37 | - | dBm |
| PAE | Power Added Efficiency | - | 40 | - | % |

Test Curves

Small Signal Gain

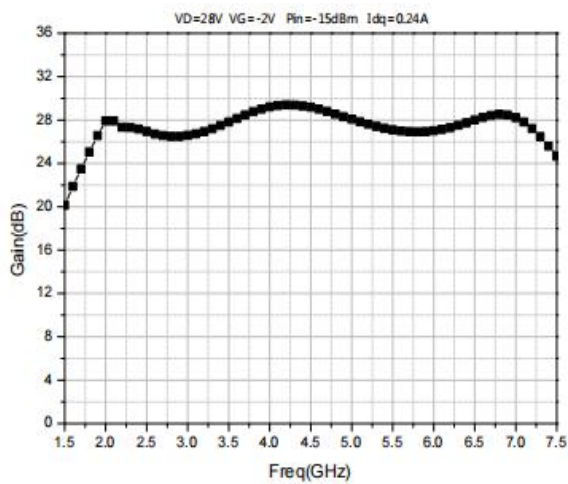

VSWRin

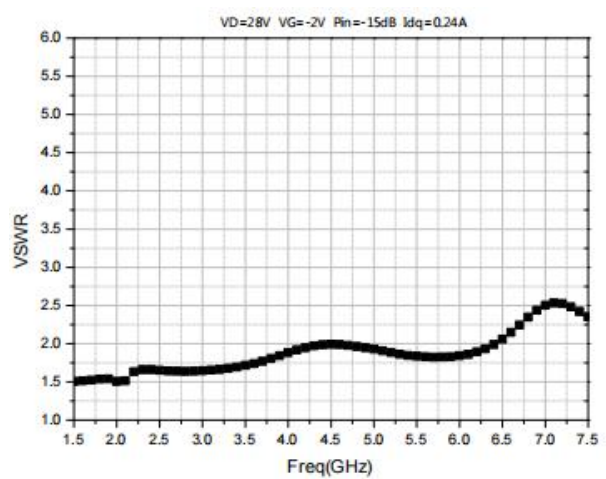

Pout@ Different Temp.

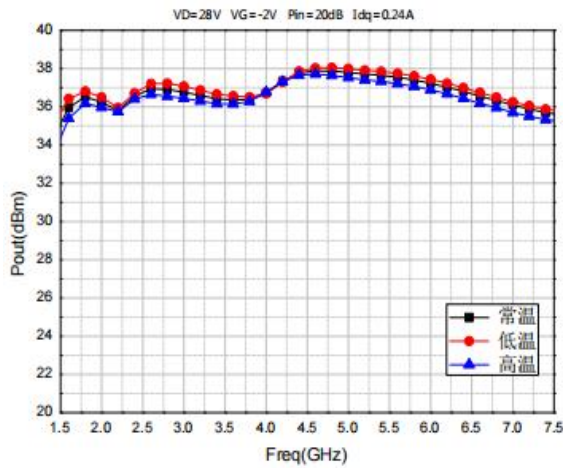

PAE@ Different Temp.

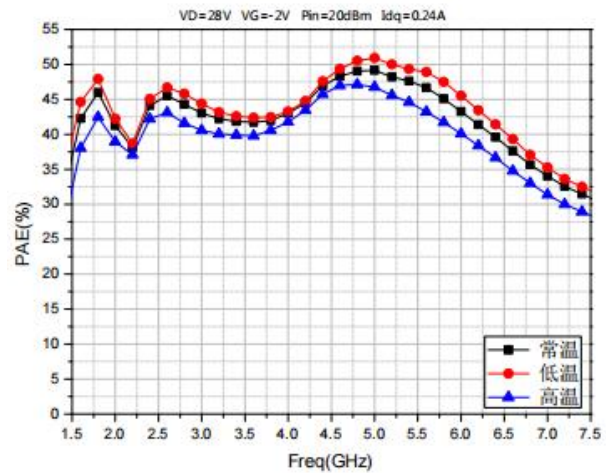

ID@ Different Temp.

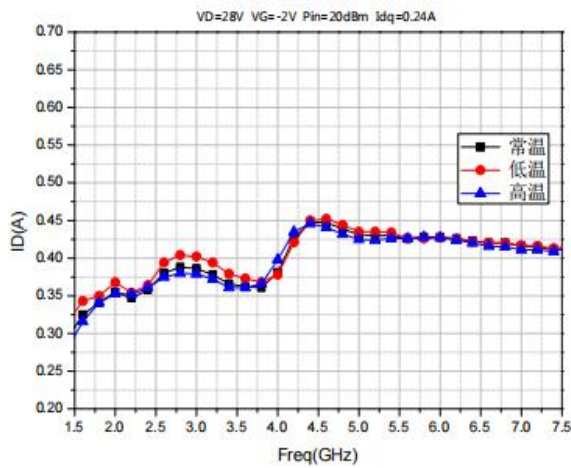

Ig@ Different Temp.

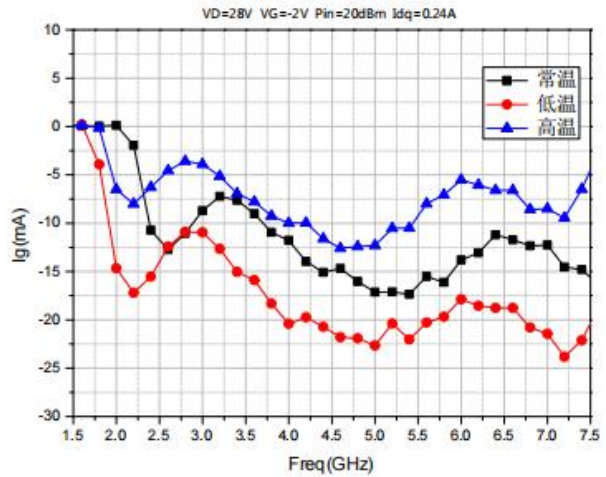



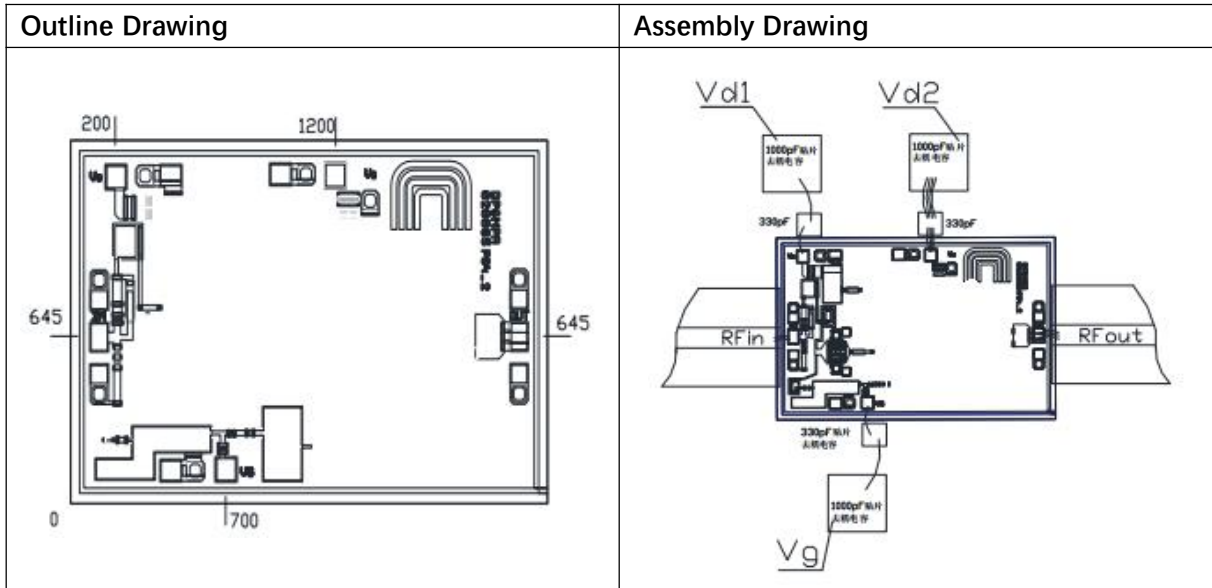

Absolute Max Ratings (TA=25°C)

| Symbol | Parameter | Value | Remark |
|--------|----------------------|-----------|----------------------|
| Vd | Drain Voltage | 32V | |
| Id | Drain Current | 0.6A | |
| Vg | Grid Voltage | -10V | |
| Ig | Grid Current | 30mA | |
| Pd | DC Power | 13W | |
| Pin | Input Power | 25dBm | |
| Tch | Channel Temperature | 225°C | |
| Tm | Mounting Temperature | 310°C | 1 min, N2 Protection |
| Tstg | Storage Temperature | -55~175°C | |

Exceeding any one or combination of these limits may cause permanent damage.

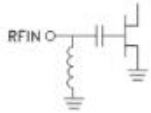

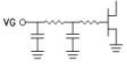
Pads Definition

| Pad | Description | Equivalent Circuit |
|-------------|---|---|
| RFIn | RF Signal input, connect to 50ohm system, block capacitor is needed if there's external DC applied on this pad. |  |
| RFout | RF Signal output, connect to 50ohm system, no need block capacitor. |  |
| VG | Amp gate bias, external 330pF, 1000pF capacitor is needed |  |
| VD1、VD2、VD3 | Amp drain bias, external 330pF, 1000pF capacitor is needed |  |
| GND | Bottom must connect to RF and DC ground | |