

Performance

- Frequency: 2.7~3.5GHz
- Typical Signal Gain: 30dB
- Typical Pout: 50.5dBm
- PAE: 51%
- Bias: -2V, 40V
- Static operating current: 2.9A
- Dynamic operating current: 5.6A
- Technology: 0.25um HEMT
- Size: 5.6mm*4.4mm*0.08mm

Function Diagram

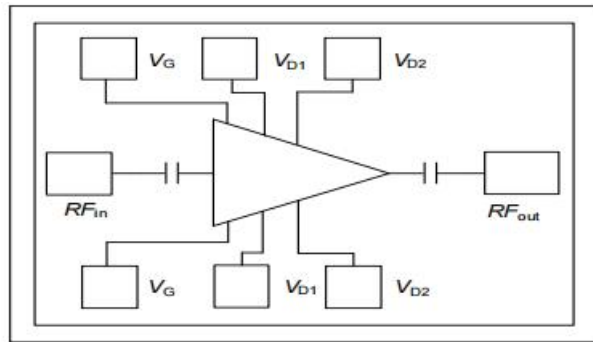

Electrical Specifications (T_A=25°C, V_g=-2V, V_d=40V(1ms,10%), F: 2.7~3.5GHz,PL)

Symbol	Parameter	Min	Typical	Max	Unit
G	Small Signal Gain	-	30	-	dB
G _p	Power Gain	-	21.5	-	dB
P _{out}	Saturated Power	-	50.5	-	dBm
I _d	Operating Current	-	5.6	-	A
PAE	Power Added Efficiency	-	51.0	-	%

Test Curves

VSWR_{in}@ Different Temp.

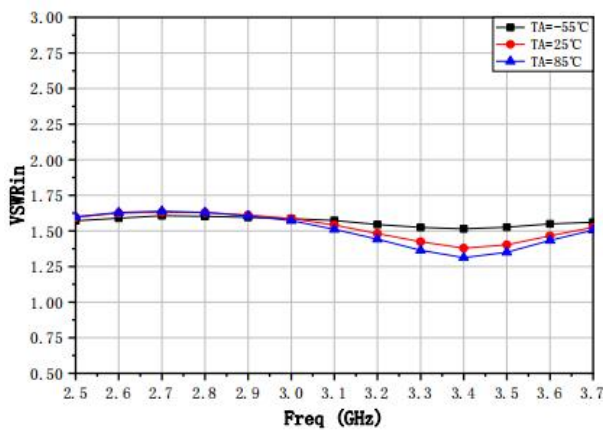

G_{lin}@ Different Temp.

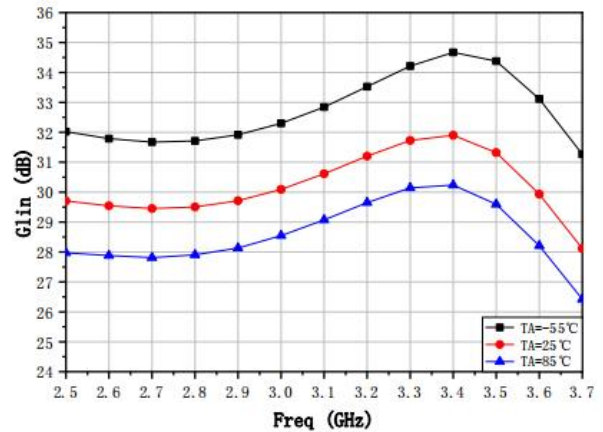

Pout@ Different Temp.

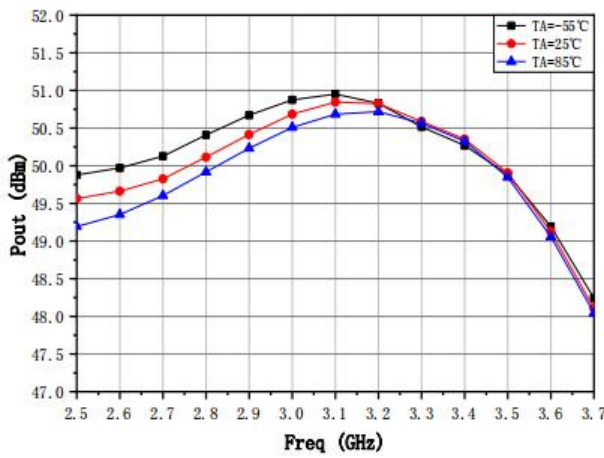

PAE@ Different Temp.

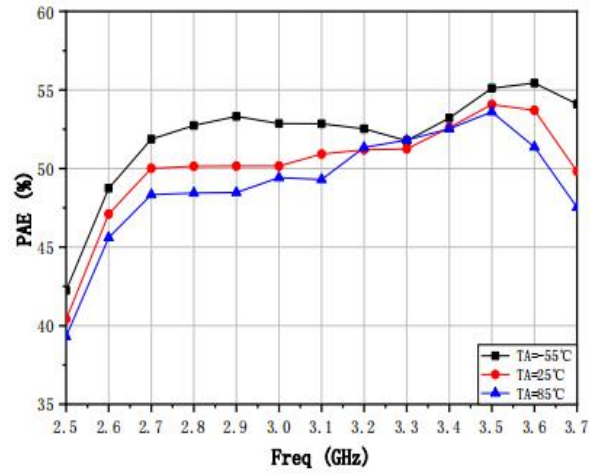

Id@ Different Temp.

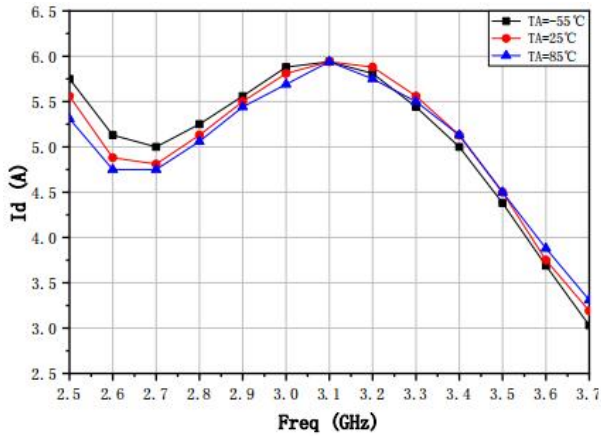

Ig@ Different Temp.

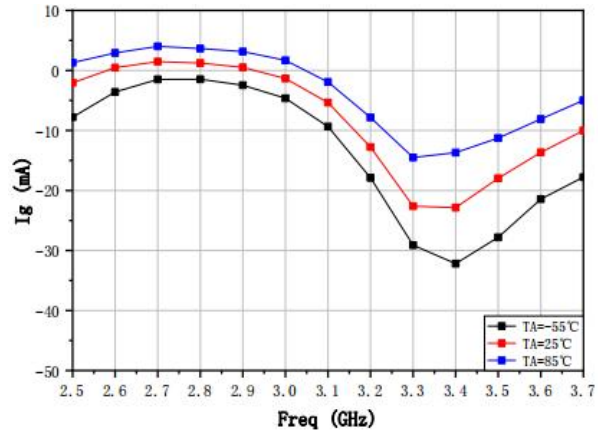

Absolute Max Ratings (TA=25°C)

Symbol	Parameter	Value	Remark
Vd	Drain Voltage	50V	
Id	Drain Current	6.5A	
Pd	DC Power	60W	
Pin	Input Power	33dBm	
Tch	Channel Temperature	225°C	
Tm	Mounting Temperature	310°C	30 s, N2 Protection
Tstg	Storage Temperature	-65~150°C	

Exceeding any one or combination of these limits may cause permanent damage.

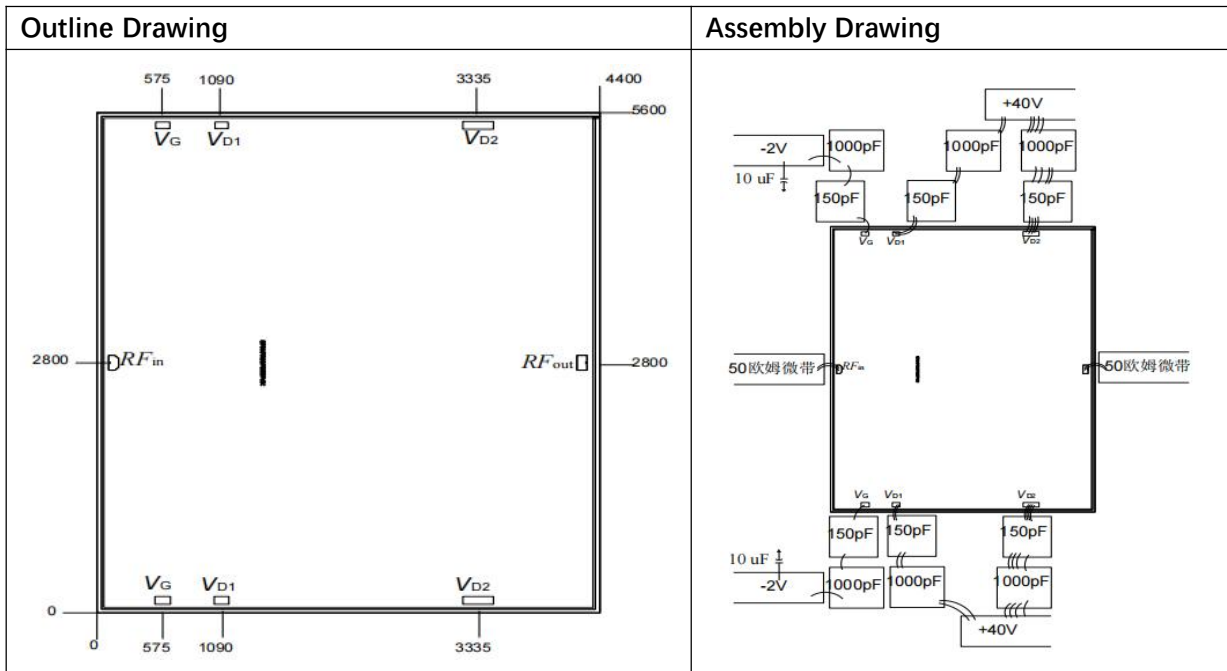

Pads Definition

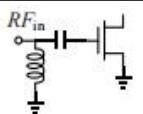
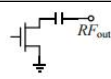
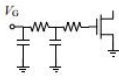
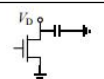
Pad	Description	Equivalent Circuit
RFin	RF Signal input, connect to 50ohm system, block capacitor is needed if there's external DC applied on this pad.	
RFout	RF Signal output, connect to 50ohm system, no need block capacitor.	
VG	Amp gate bias, external 150pF, 1000pF, 10uF capacitor is needed	
VD1、VD2	Amp drain bias, external 150pF, 1000pF capacitor is needed	
GND	Bottom must connect to RF and DC ground	