

Performance

- Frequency: 50~75GHz
- Typical Signal Gain: 26.2dB
- Typical Pout: 34.3dBm@15V
- PAE: 15.7%
- VSWR:1.5
- Power Gain:14.3dB
- Static Current: 0.86A
- Dynamic Current: 1.10A
- Bias: 15V, -2V (Typ.)
- Mode: CW
- Size: 4.9m*3.2mm*0.05mm

Function Diagram

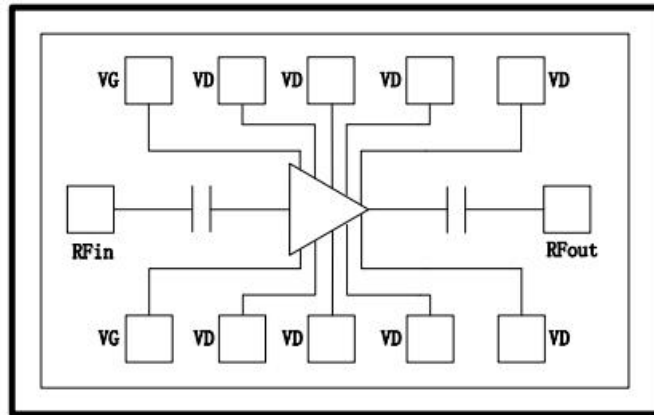

Electrical Specifications (TA=25°C, Vd=15V, Idq=0.86A , F: 50~75GHz , CW)

Symbol	Parameter	Min	Typical	Max	Unit
G	Small Signal Gain	-	26.2	-	dB
Gp	Power Gain	13.6	-	-	dB
Pout	Saturated Power	33.6	-	-	dBm
PAE	Power Added Efficiency	-	15.7	-	%

Test Curves

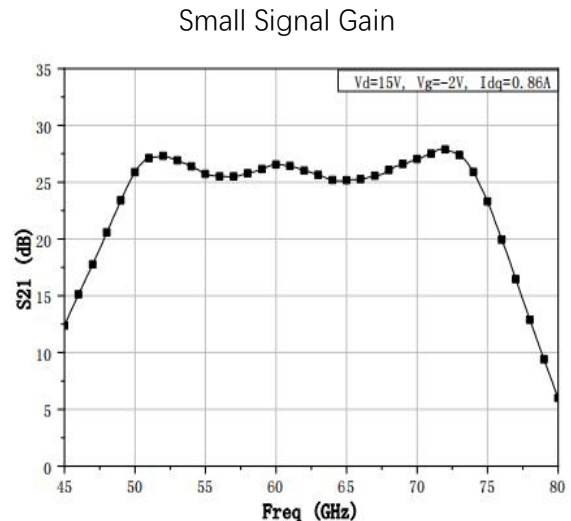
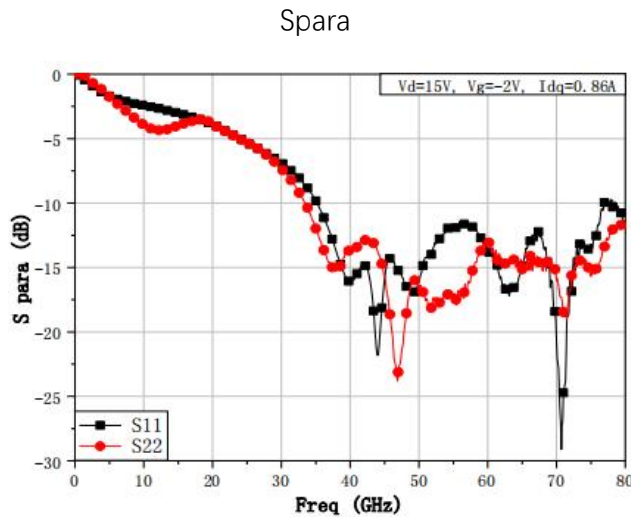

Pout@ Different Temp.

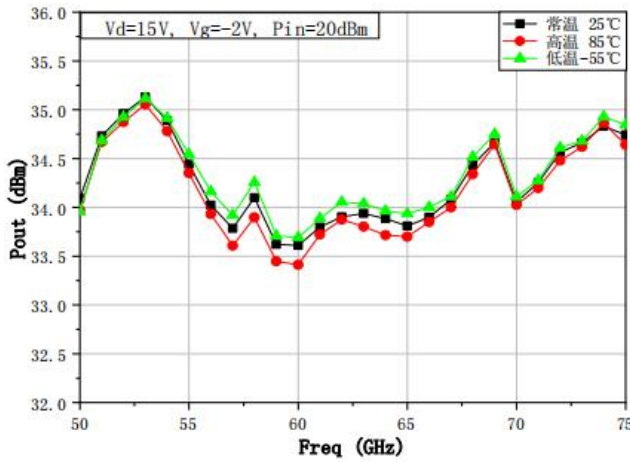

PAE@ Different Temp.

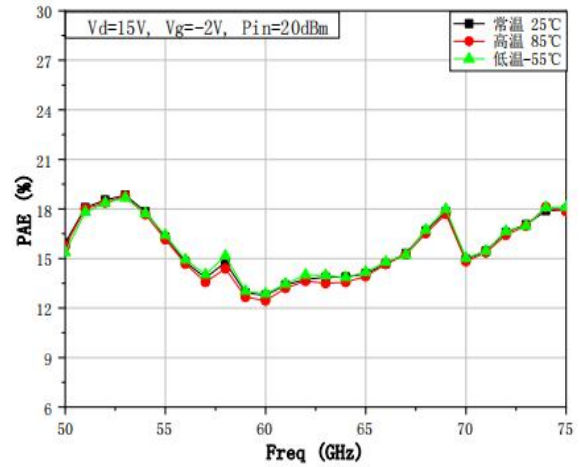

PoutGain@ Different Temp.

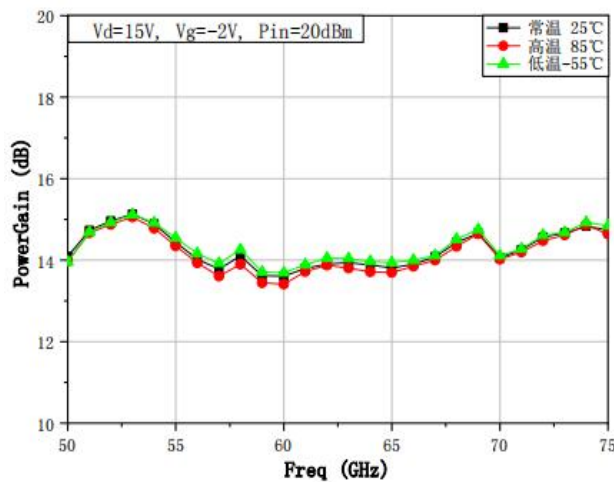

Pout@ Different Vd

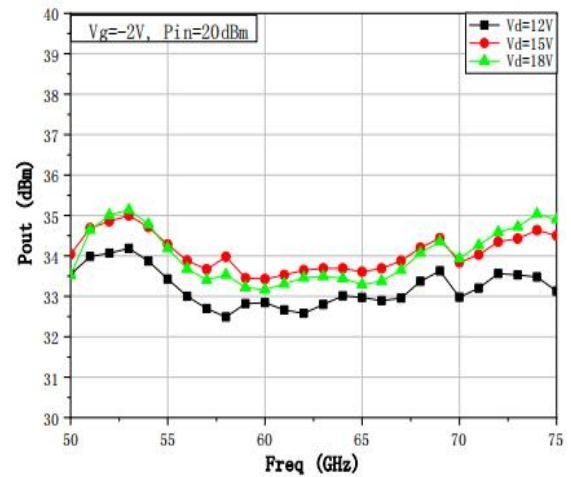

PAE@ Different Vd

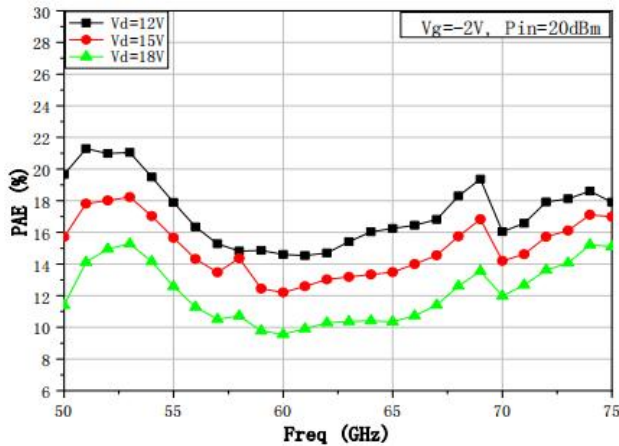

Id@ Different Vd

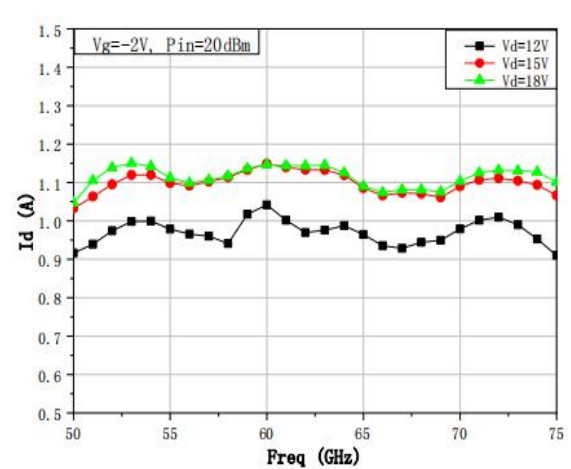

Pout@ Different Pin

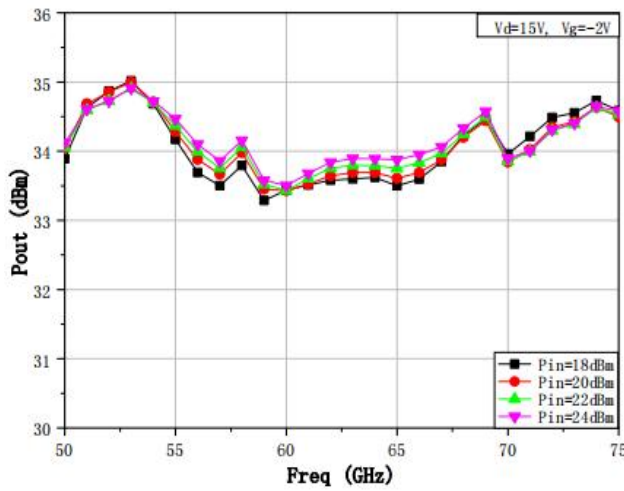

PAE@ Different Pin

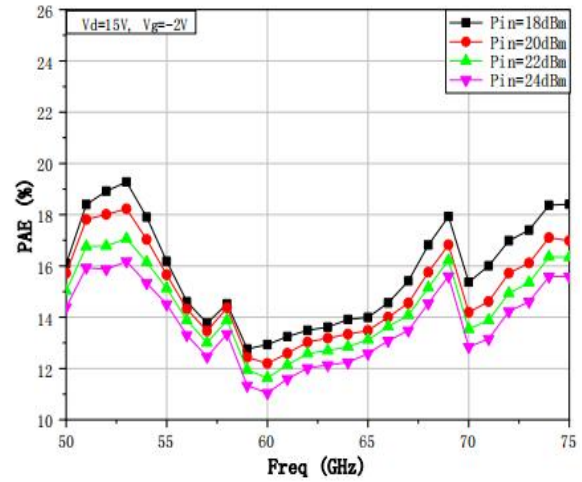



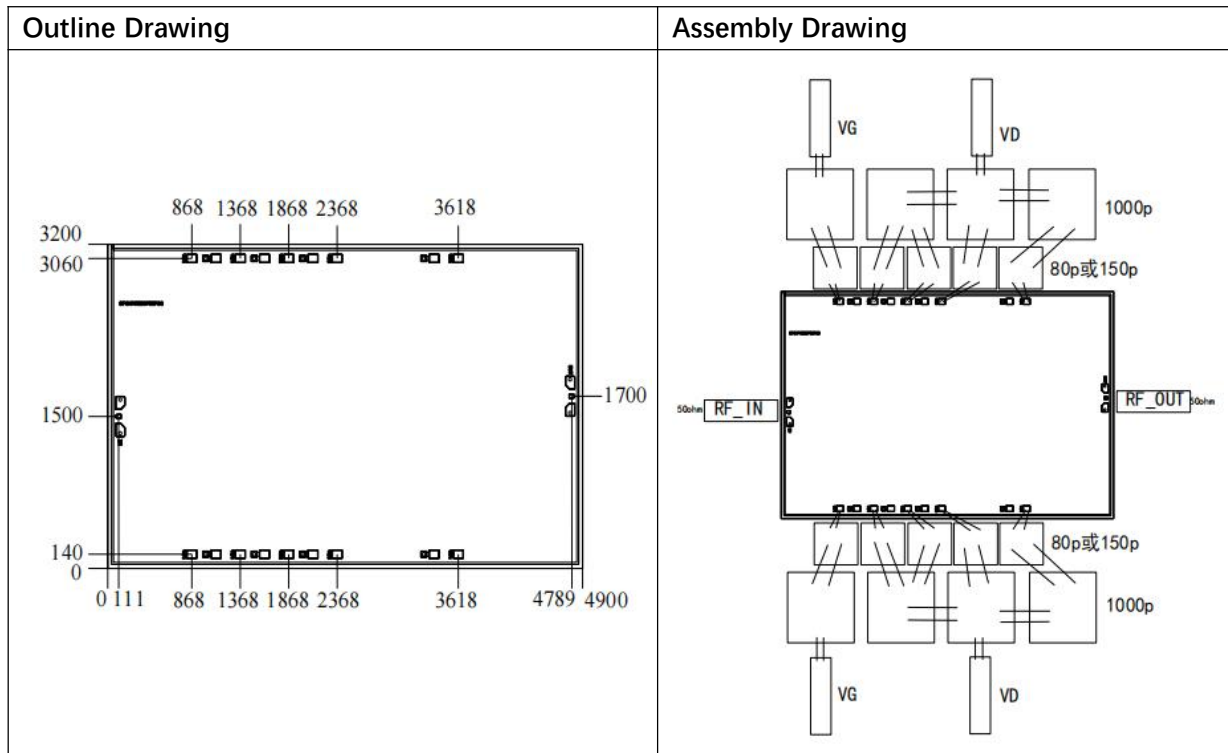

Absolute Max Ratings (TA=25°C)

Symbol	Parameter	Value	Remark
Vd	Drain Voltage	18V	
Id	Drain Current	1.5A	
Vg	Grid Voltage	-3V	
Ig	Grid Current	10mA	
Pd	DC Power	27W	
Pin	Input Power	30dBm	
Tch	Channel Temperature	200°C	
Tm	Mounting Temperature	290°C	1 min, N2 Protection
Tstg	Storage Temperature	-55~150°C	

Exceeding any one or combination of these limits may cause permanent damage.

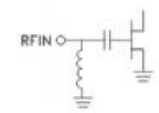

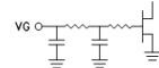
Pads Definition

Pad	Description	Equivalent Circuit
RFin	RF Signal input, connect to 50ohm system, no need block capacitor.	
RFout	RF Signal output, connect to 50ohm system, no need block capacitor.	
VG	Amp gate bias, external 1000pF capacitor is needed	
VD1、VD2、VD3	Amp drain bias, external 100pF capacitor is needed	
GND	Bottom must connect to RF and DC ground	