

### Performance

- Frequency: 8~12GHz
- Typical Signal Gain: 31dB
- Typical Pout: 42dBm@28V
- PAE: 45%
- Bias: 28V, -2V(Typ.)
- Technology: 0.25um HEMT
- Size: 2.8\*1.6mm\*0.08mm

### Function Diagram

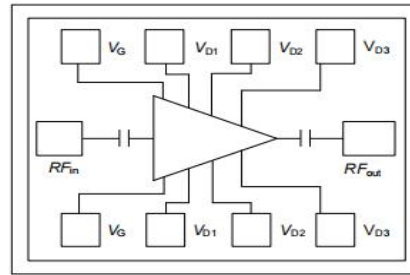

### Electrical Specifications (T<sub>A</sub>=25°C, V<sub>d</sub>=28V, I<sub>dq</sub>=0.78A, F: 8~12GHz, PL-0.1ms-10%)

Symbol	Parameter	Min	Typical	Max	Unit
G	Small Signal Gain	-	31	-	dB
G <sub>p</sub>	Power Gain	-	22	-	dB
P <sub>out</sub>	Saturated Power	-	42	-	dBm
PAE	Dynamic current	-	45	-	%

### Test Curves

Small Signal Gain

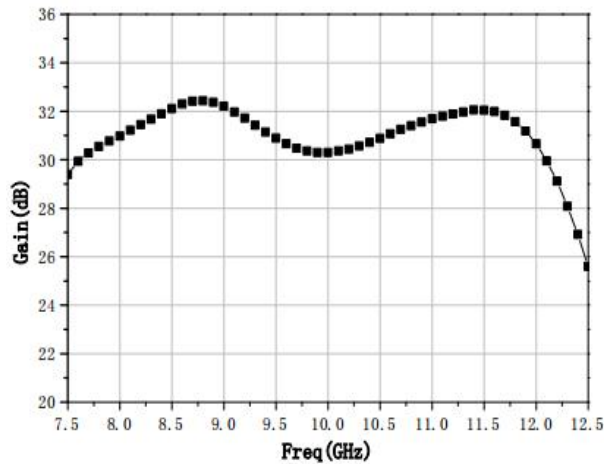

VSWR<sub>in</sub>

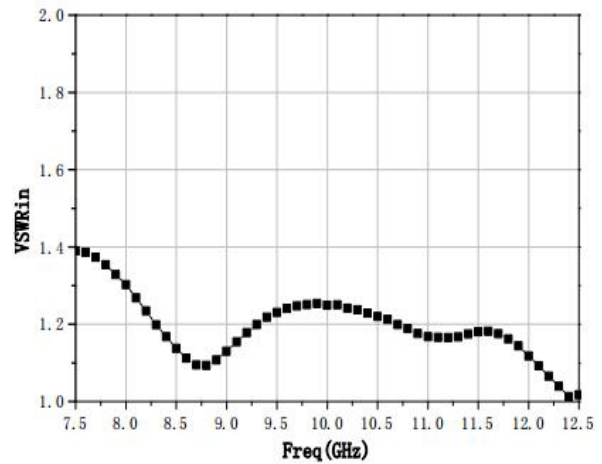

Pout

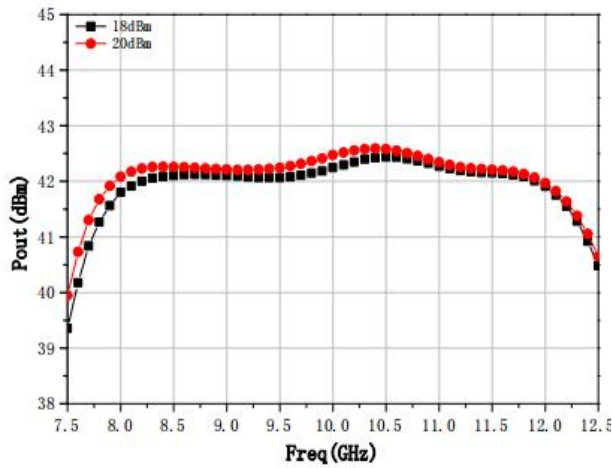

PAE

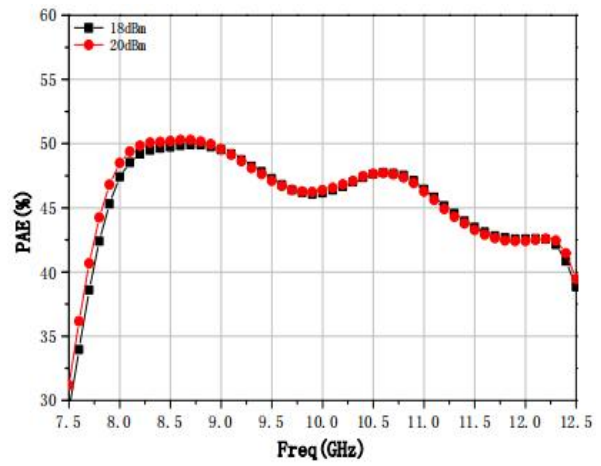

Id

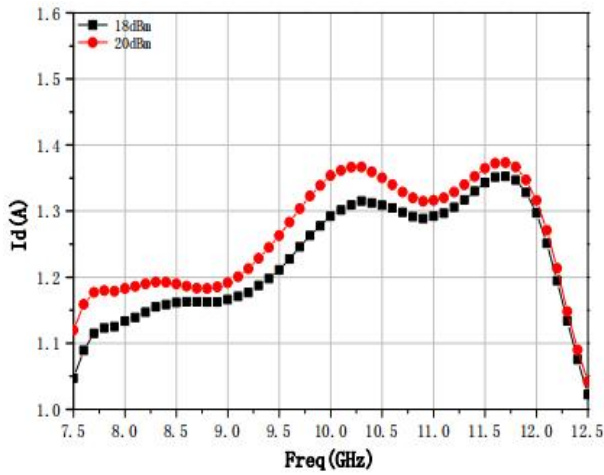

Ig

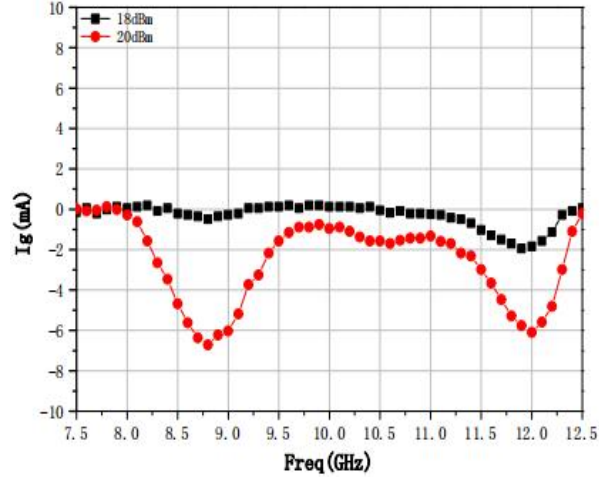

SHS

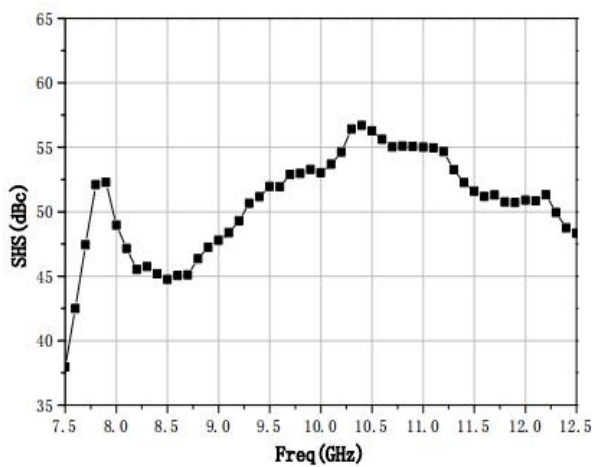

THS

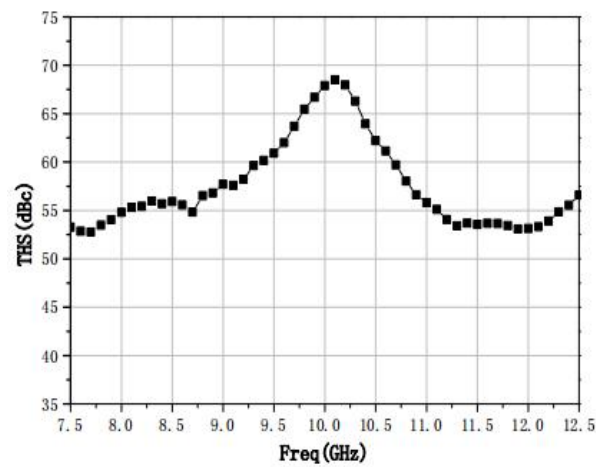

**Absolute Max Ratings (TA=25°C)**

Symbol	Parameter	Value	Remark
Vd	Drain Voltage	32V	
Id	Drain Current	1.8A	
Vg	Gate Voltage	-10V	
Ig	Gate Current	10mA	
Pd	DC Power	50W	
Pin	Input Power	23dBm	
Tch	Channel Temperature	175°C	
Tm	Mounting Temperature	310°C	1 min, N2 Protection
Tstg	Storage Temperature	-55~175°C	

Exceeding any one or combination of these limits may cause permanent damage.

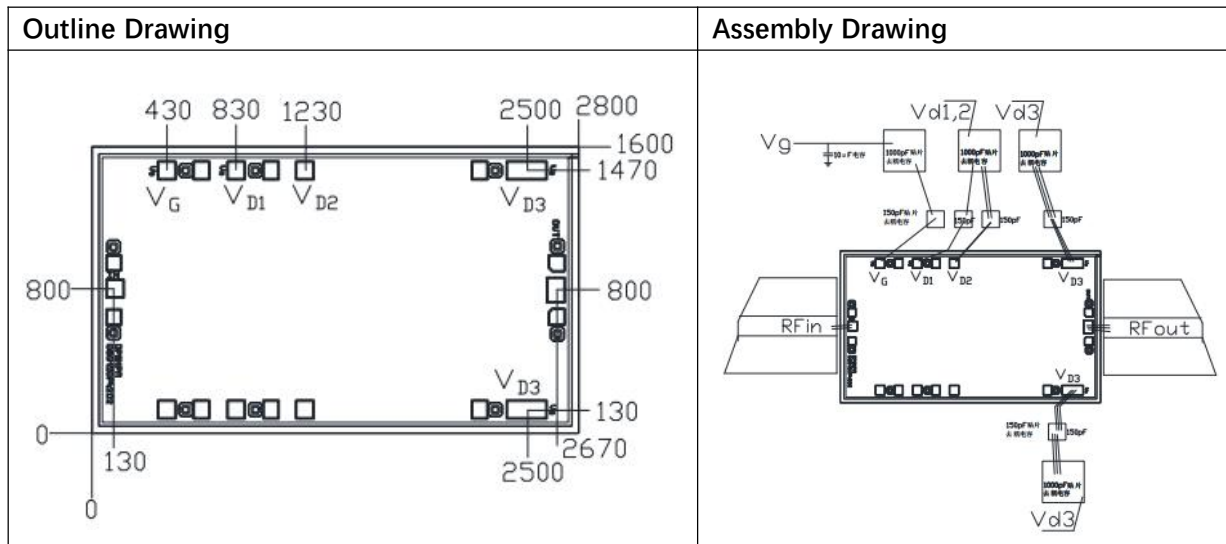

**Pads Definition**

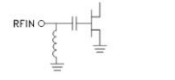
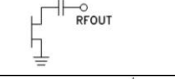
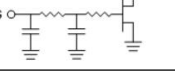
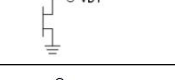
Pad	Description	Equivalent Circuit
RFin	RF Signal input, connect to 50ohm system, no need block capacitor.	
RFout	RF Signal output, connect to 50ohm system, no need block capacitor.	
VG	Amp gate bias, external 150pF, 1000pF, 1uF capacitor is needed	
VD1, VD2, VD3	Amp drain bias, external 150pF, 1000pF capacitor is needed	
GND	Bottom must connect to RF and DC ground	