

Performance

- Frequency: 4~10GHz
- Typical Signal Gain: 33dB
- Typical Pout: 45dBm
- Typical PAE: 40%
- Bias: 28V, -1.8V
- Technology: 0.25um HEMT
- Size: 3.8*3.1mm*0.08mm

Function Diagram

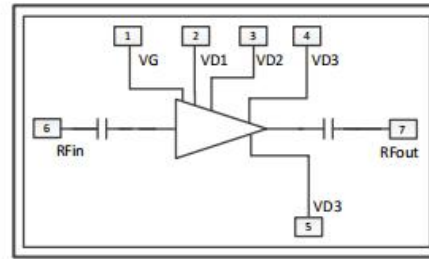

Electrical Specifications (TA=25°C, Vd=28V, Vg=-1.8V, F: 4~10GHz, 1ms/10%)

Symbol	Parameter	Min	Typical	Max	Unit
G	Small Signal Gain	-	32	-	dB
Gp	Power Gain	-	22	-	dB
Pout	Saturated Power	-	45	-	dBm
Id	Dynamic Current	-	3.1	-	A

Test Curves

Small Signal Gain@ Different Temp

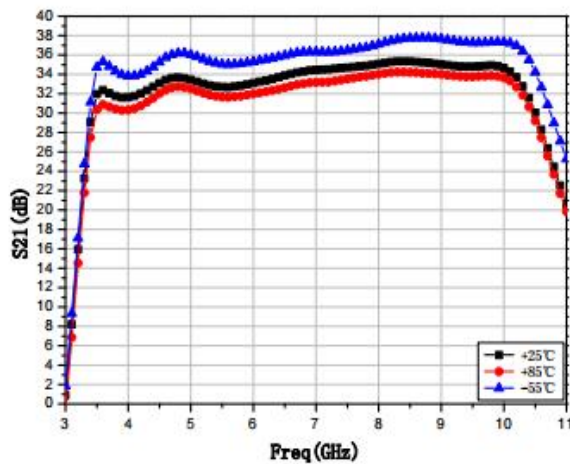

VSWRin@ Different Temp

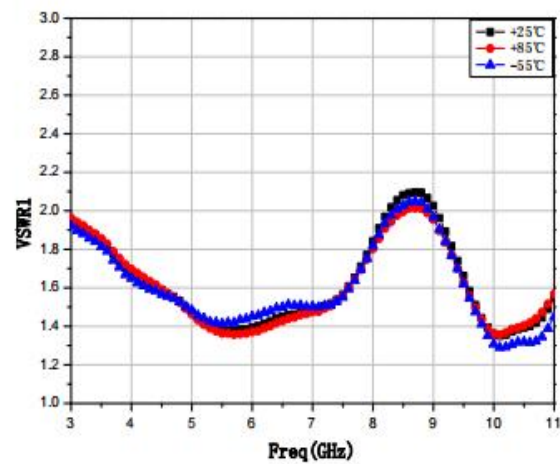

Gain@ Different Vd

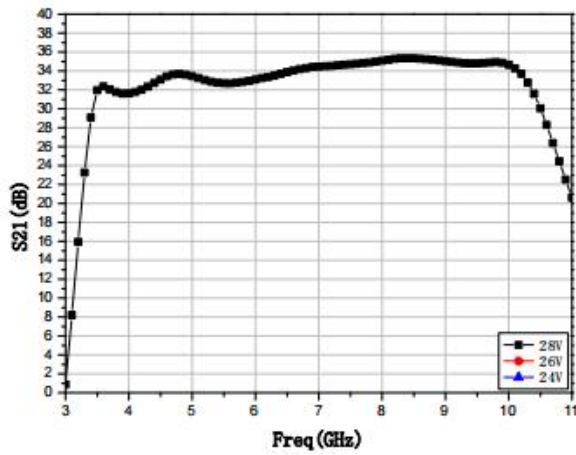

VSWRin@ Different Vd

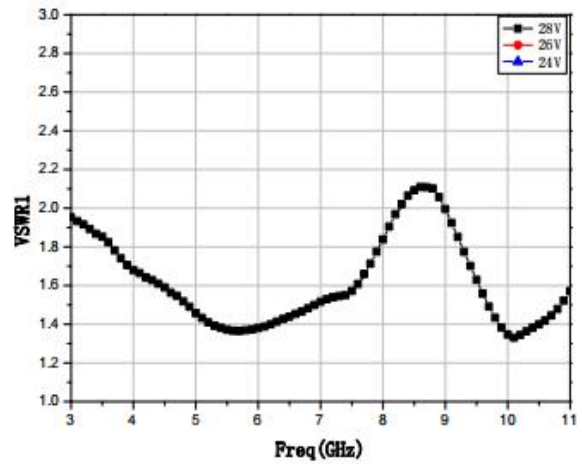

Pout@ Different Temp.

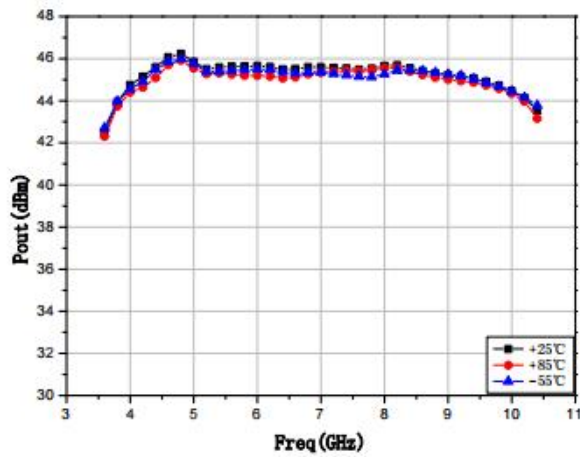

PAE@ Different Temp.

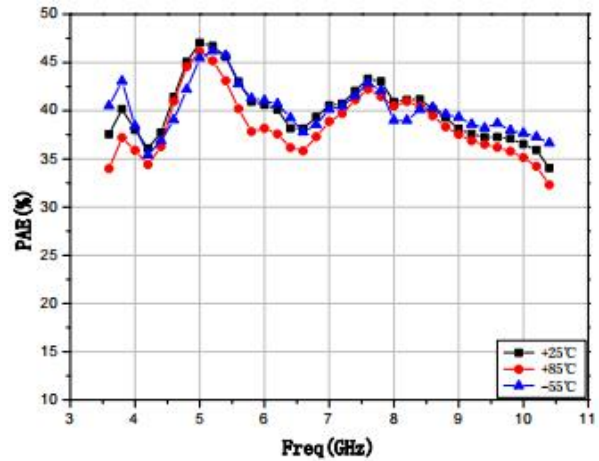

Pout@ Different Vd

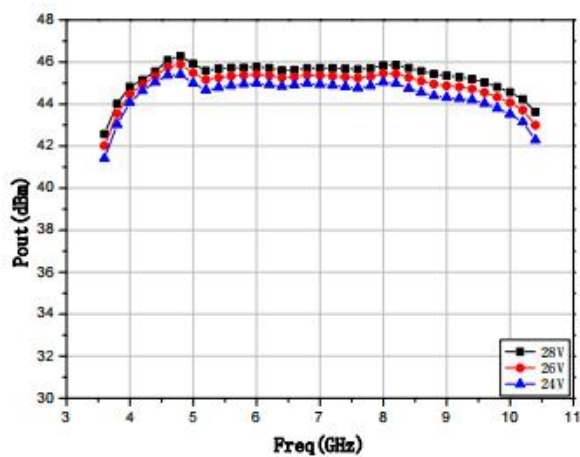

PAE@ Different Vd

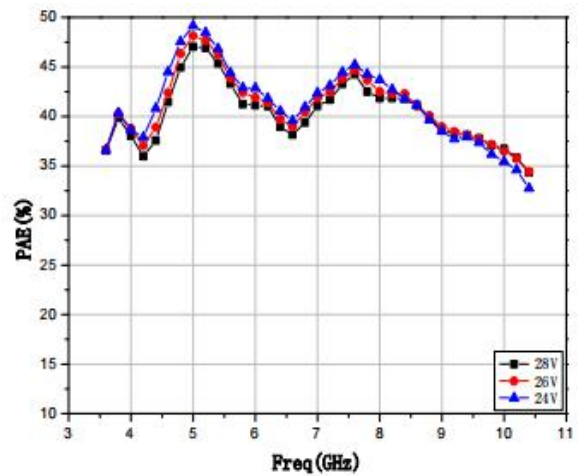

Pout@ Different Pin

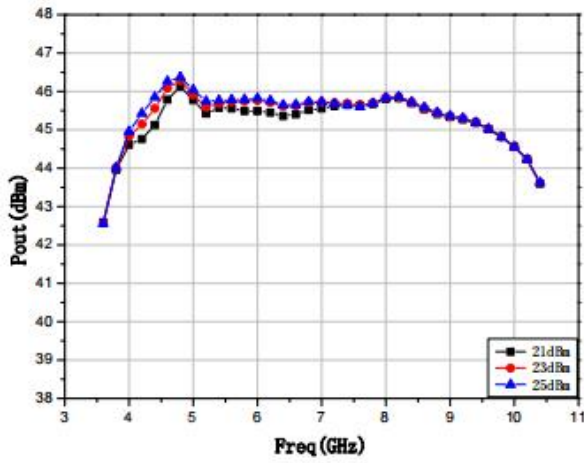

PAE@ Different Pin

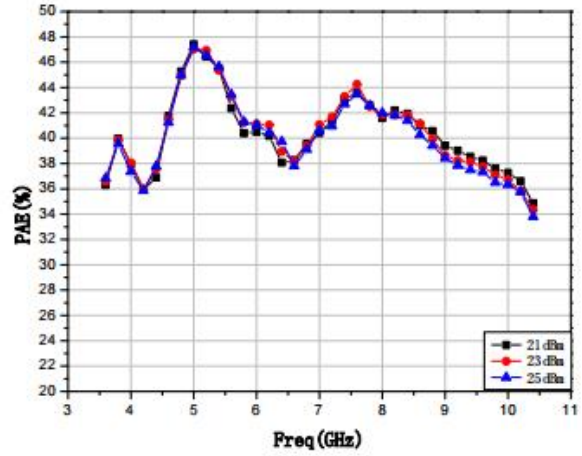

Id@ Different Pin

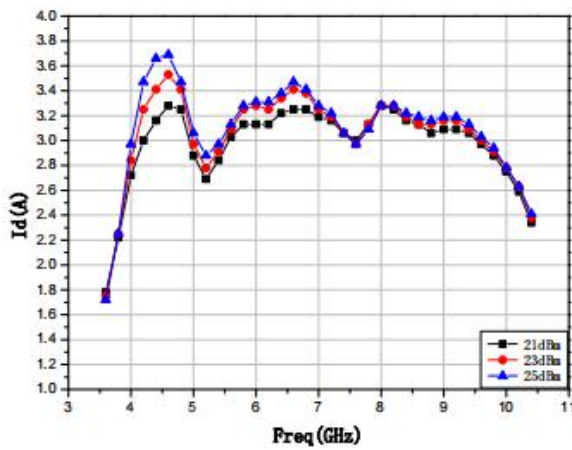

Ig@ Different Pin

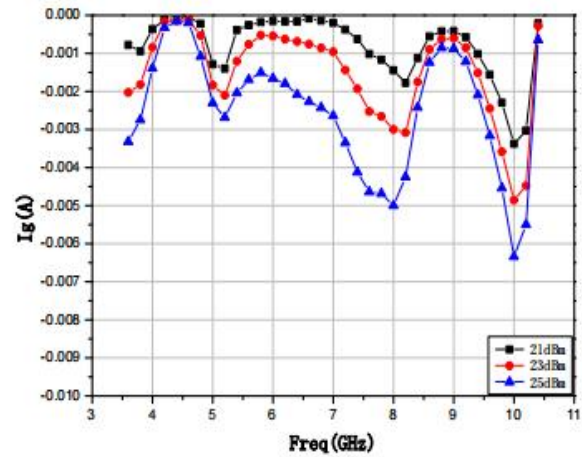

Id@ Different Vd

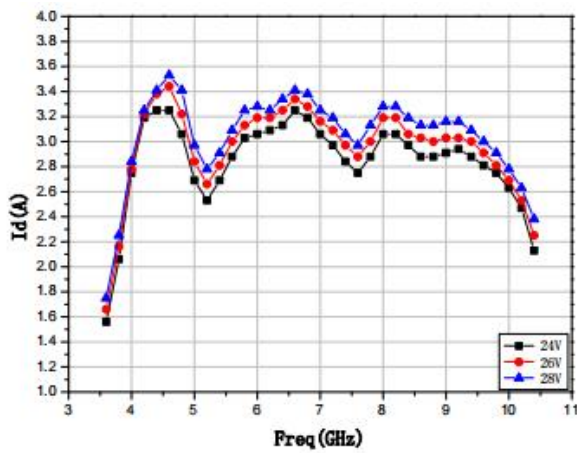

Ig@ Different Vd

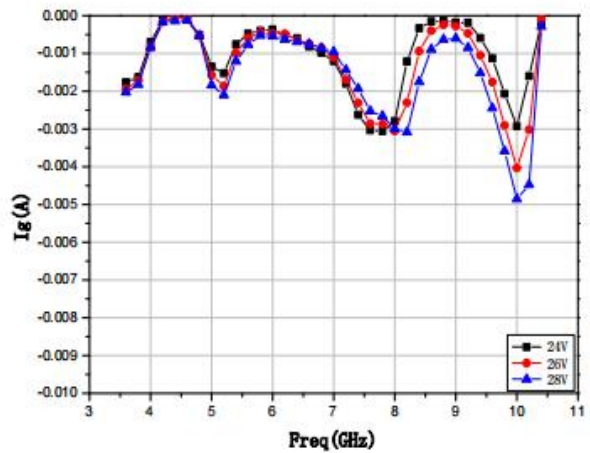



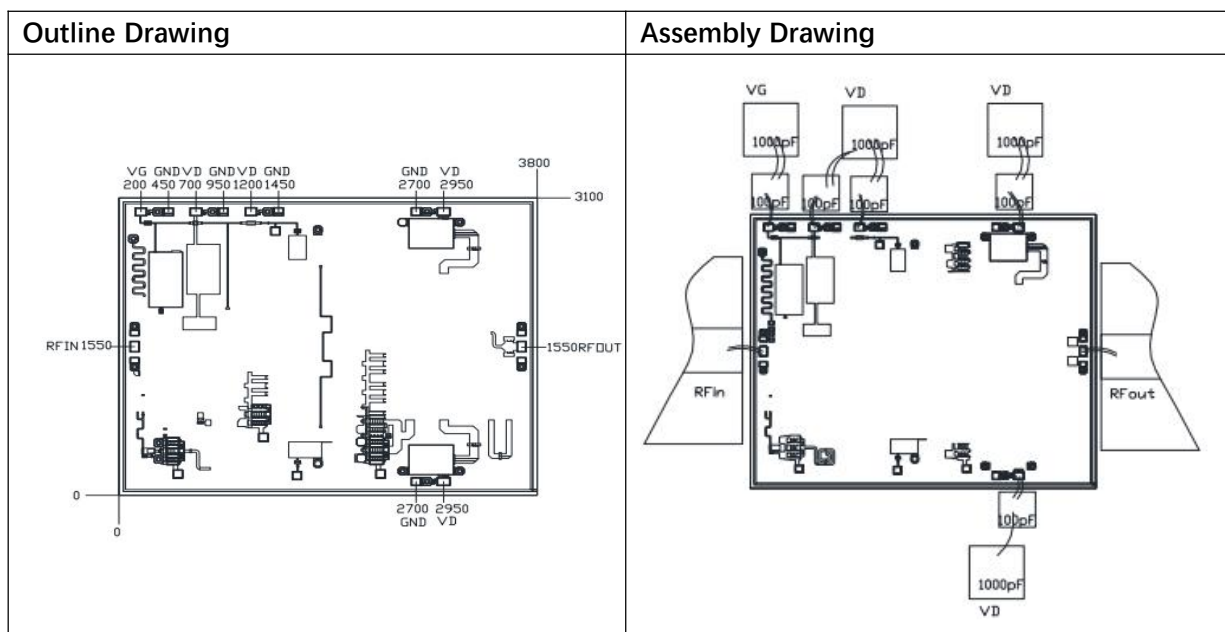

Absolute Max Ratings (TA=25°C)

Symbol	Parameter	Value	Remark
Vd	Drain Voltage	32V	
Id	Drain Current	4A	
Pd	DC Power	80W	
Pin	Input Power	30dBm	
Tch	Channel Temperature	225°C	
Tm	Mounting Temperature	310°C	1 min, N2 Protection
Tstg	Storage Temperature	-55~175°C	

Exceeding any one or combination of these limits may cause permanent damage.

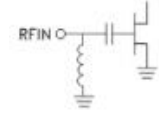

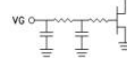
Pads Definition

Pad	Description	Equivalent Circuit
RFin	RF Signal input, connect to 50ohm system, no need block capacitor.	
RfOut	RF Signal output, connect to 50ohm system, no need block capacitor.	
VG	Amp gate bias, external 100pF, 1000pF capacitor is needed	
VD	Amp drain bias, external 100pF, 1000pF capacitor is needed	
GND	Bottom must connect to RF and DC ground	