

Performance

- Frequency: 32~33GHz
- Typical Signal Gain: 26dB
- Typical Pout: 41dBm@20.0V
- Typical PAE: 29%
- Bias: 20V, -2.4A(CW)
- Technology: GaN HEMT
- Size: 3.3*3.5mm*0.05mm

Function Diagram

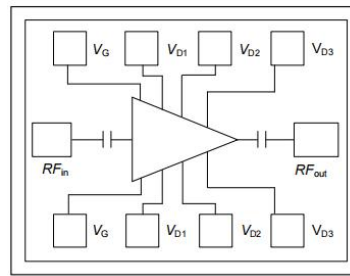

Electrical Specifications (T_A=25°C, V_d=20V, V_g=-2.4V, F:32~33GHz, Heat plate temp.=70°C)

Symbol	Parameter	Min	Typical	Max	Unit
G	Small Signal Gain	-	26	-	dB
G _p	Power Gain	-	17	-	dB
P _{out}	Saturated Power	-	41	-	dBm
I _d	Dynamic Current	-	2.3	-	A
PAE	Power Added Efficiency	-	29	-	%
IM3	3rd Harmonic	-	-25@38dBm	-	dBc
R _{th}	Thermal Resistance	-	1.7	-	°C/W

Test Curves

Small Signal Gain@ Different Temp.

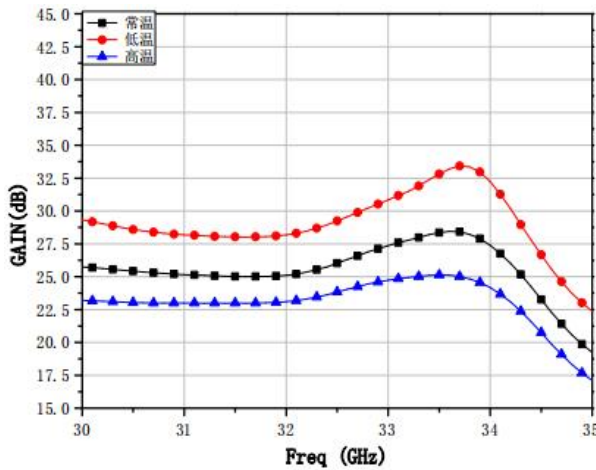

VSWRin@ Different Temp.

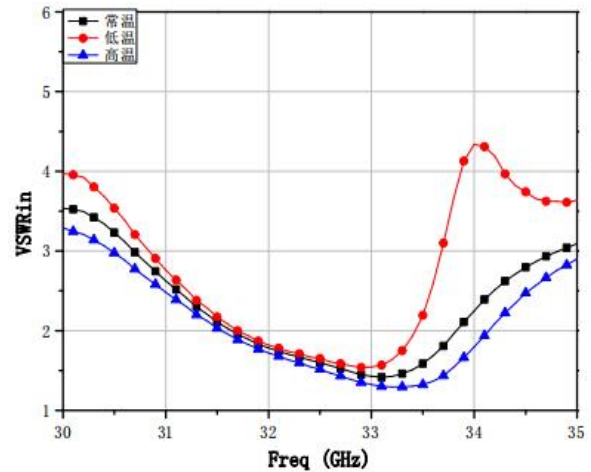

Small Signal Gain@ Different Vd

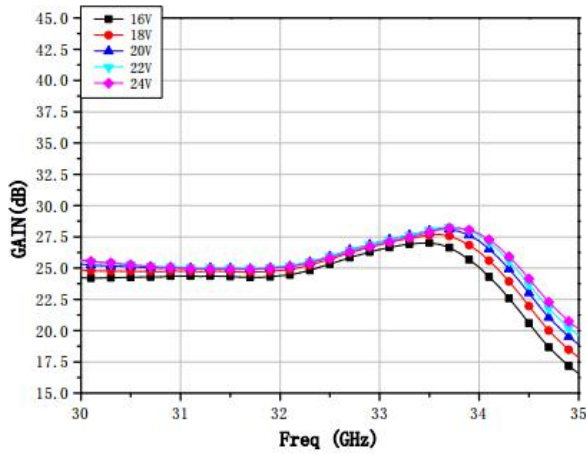

VSWRin@ Different Vd

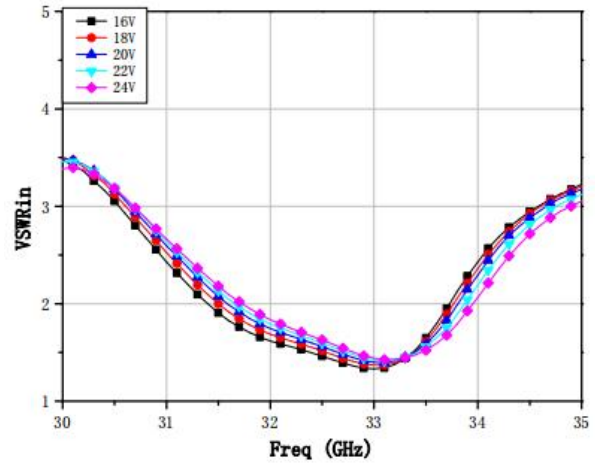

Pout@ Different Temp.

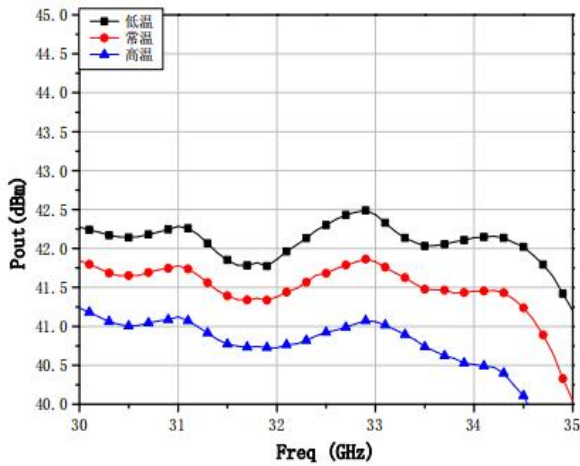

PAE@ Different Temp.

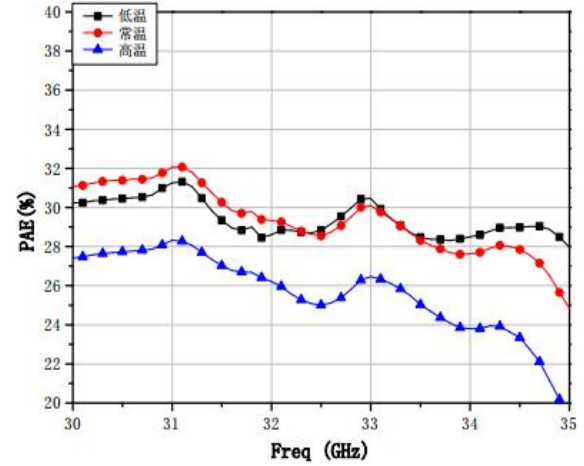

Pout@ Different Vd

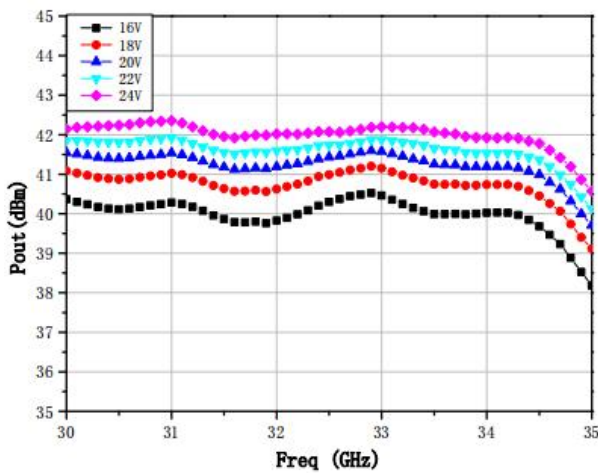

PAE@ Different Vd

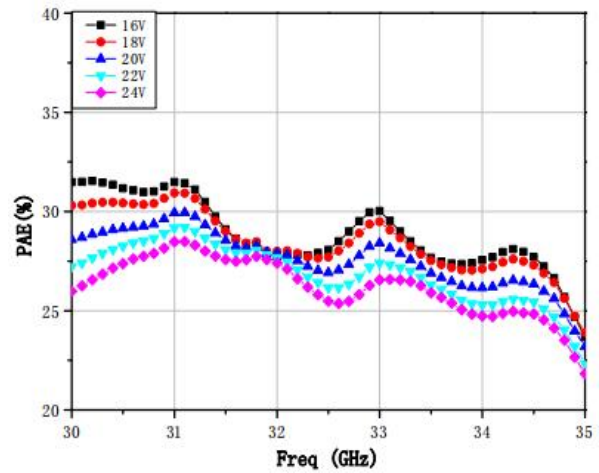

Pout@ Different Pin

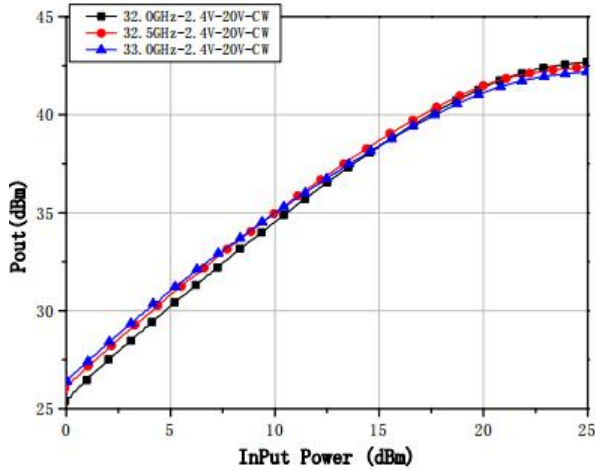

PAE@ Different Pin

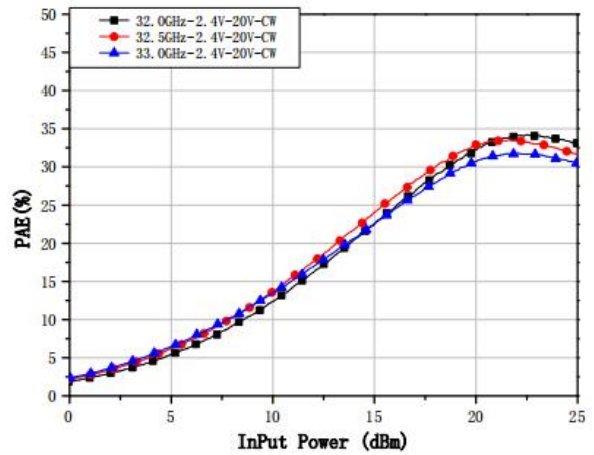

Id@ Different Pin

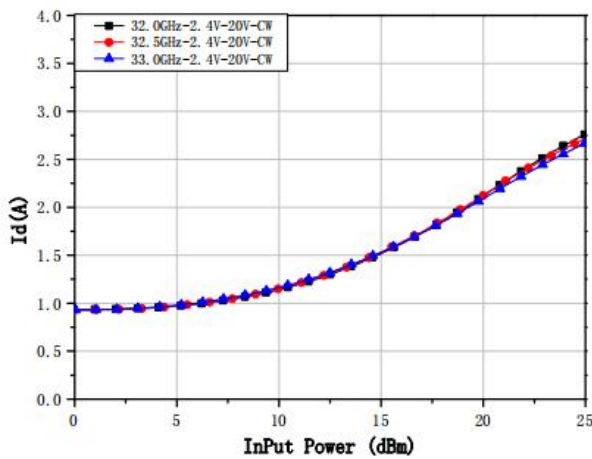

Ig@ Different Pin

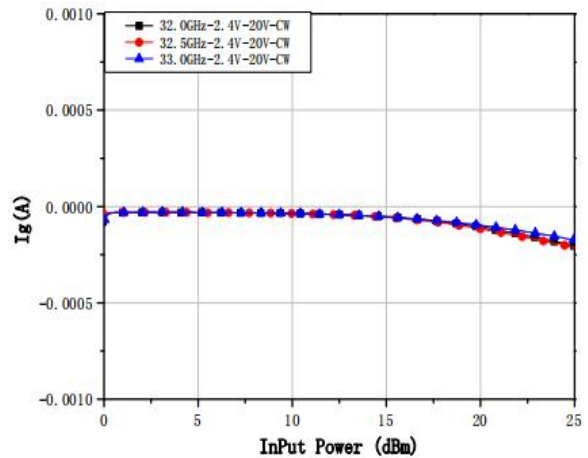

Id@ Different Vd

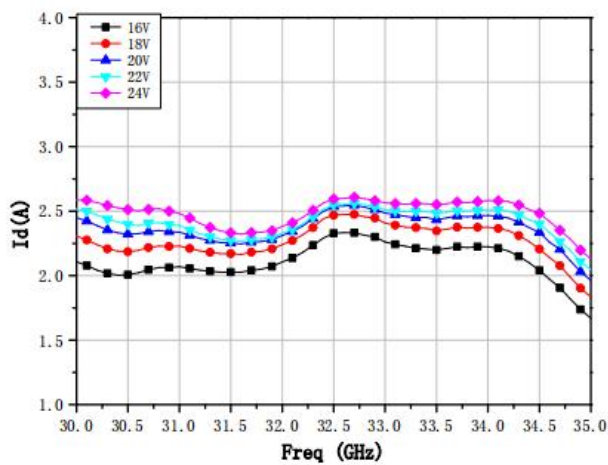

Ig@ Different Vd

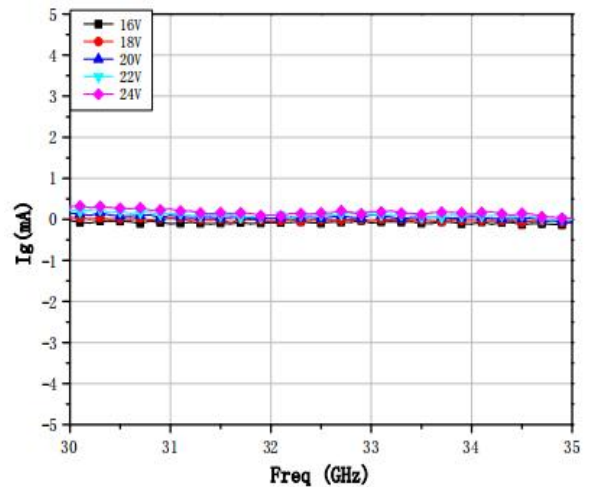

IM3 VS pout/per tone

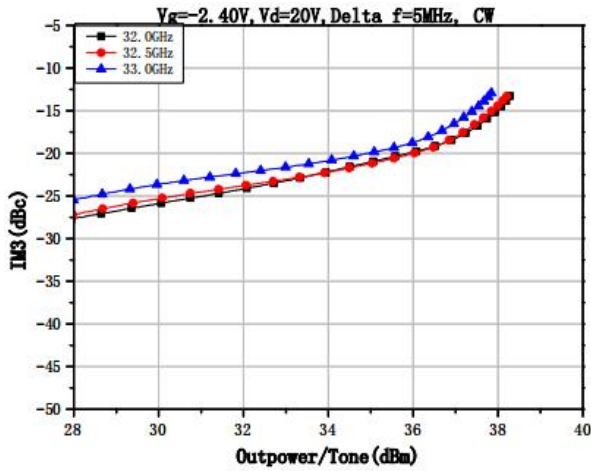

IM3 VS pout/per tone

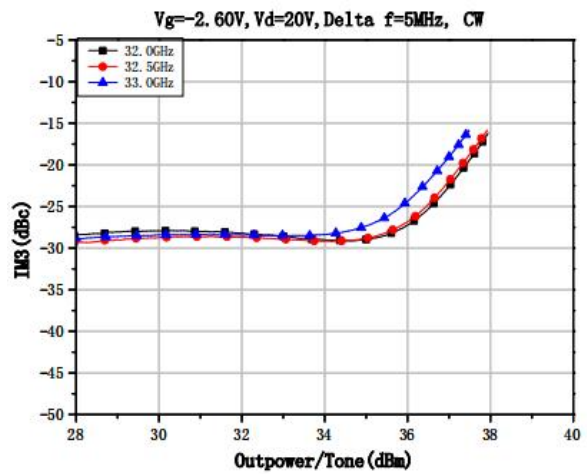

Absolute Max Ratings (TA=25°C)

Symbol	Parameter	Value	Remark
Vd	Drain Voltage	24V	
Vg	Gage Voltage	-10V	
Pd	DC Power	60W	
Pin	Input Power	30dBm	
Tch	Channel Temperature	225°C	
Tm	Mounting Temperature	310°C	1 min, N2 Protection
Tstg	Storage Temperature	-55~175°C	

Exceeding any one or combination of these limits may cause permanent damage.

Outline Drawing

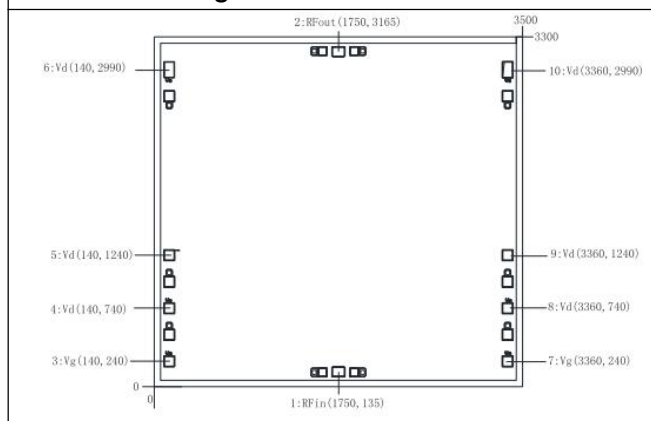

Assembly Drawing

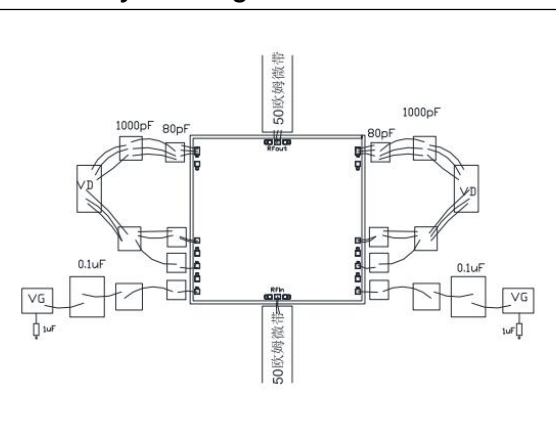

Pads Definition

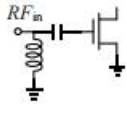
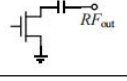
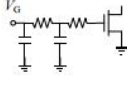
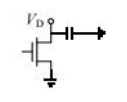
Pad	Description	Equivalent Circuit
RFin	RF Signal input, connect to 50ohm system, block capacitor is needed if there's external DC applied on this pad.	
RFout	RF Signal output, connect to 50ohm system, no need block capacitor.	
VG	Amp gate bias, external 80pF, 1000pF capacitor is needed	
VD1、VD2、VD3	Amp drain bias, external 80pF, 1000pF capacitor is needed	
GND	Bottom must connect to RF and DC ground	