

Performance

- Frequency: 92~96GHz
- Typical Signal Gain: 14.5dB
- Typical Pout: 30dBm@15V
- Typical PAE: 15.5%
- Bias: 15V, -1.5V(Typ.)
- Mode: CW
- Technology: 0.1um GaN HEMT
- Size: 3.4*1.43mm*0.05mm

Function Diagram

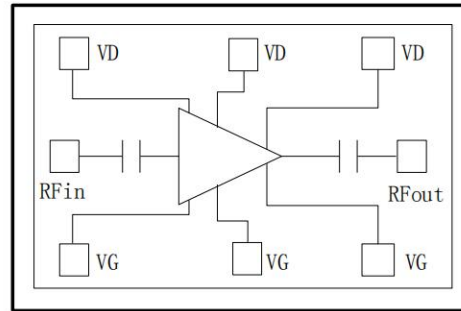

Electrical Specifications (TA=25°C, Vd=15V, Idq=0.3A, F:92~96GHz, CW)

Symbol	Parameter	Min	Typical	Max	Unit
G	Small Signal Gain	-	14.5	-	dB
Gp	Power Gain	10	-	-	dB
Pout	Saturated Power	30	-	-	dBm
PAE	Power Added Efficiency	-	15.5	-	%

Test Curves

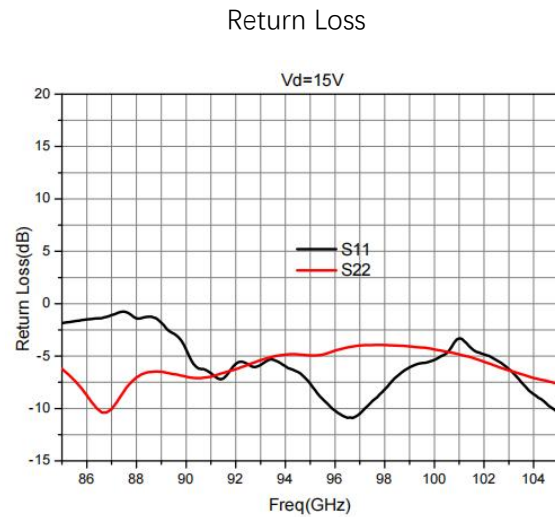
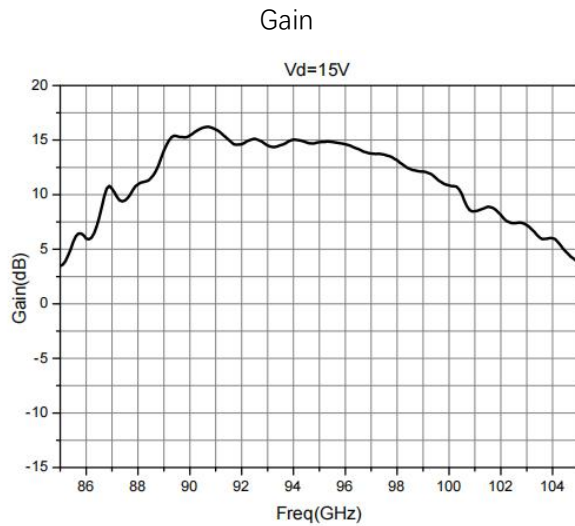

Pout, Gp, PAE

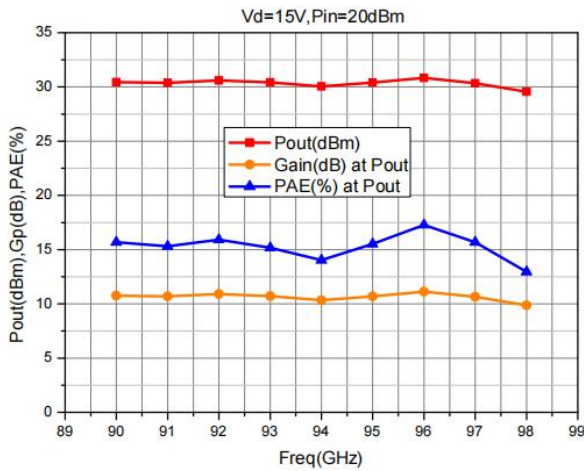

Pout, PAE, Power Gain

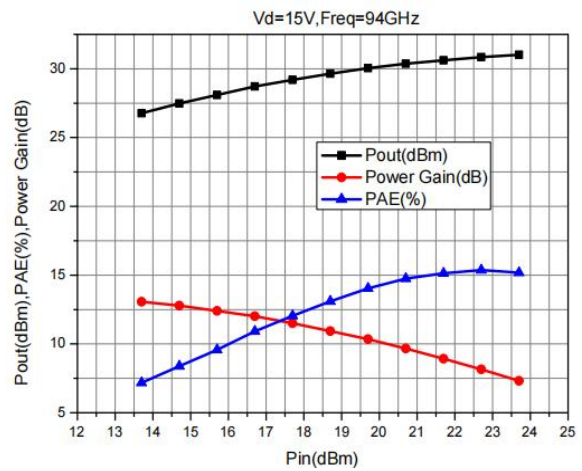

Pout@ Different Freq

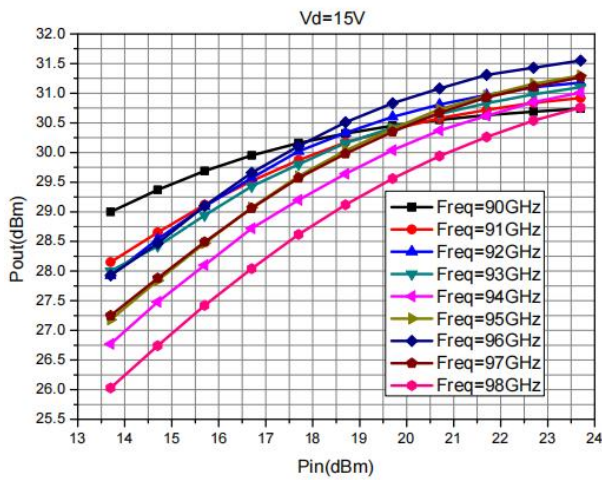

Pout@ Different Pin

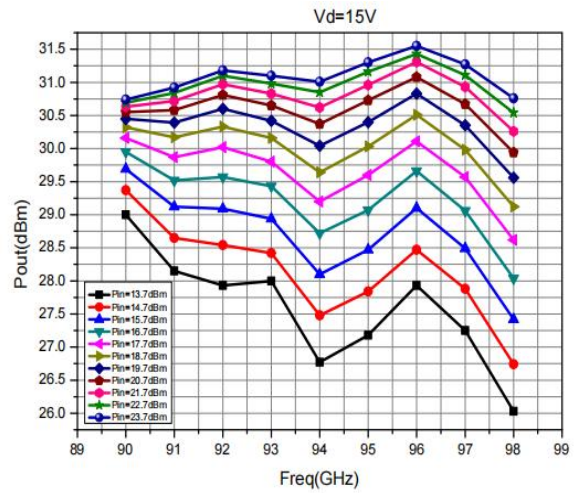

Pout

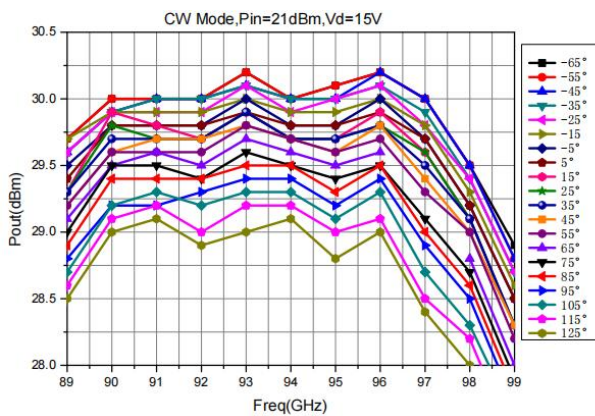

Pout

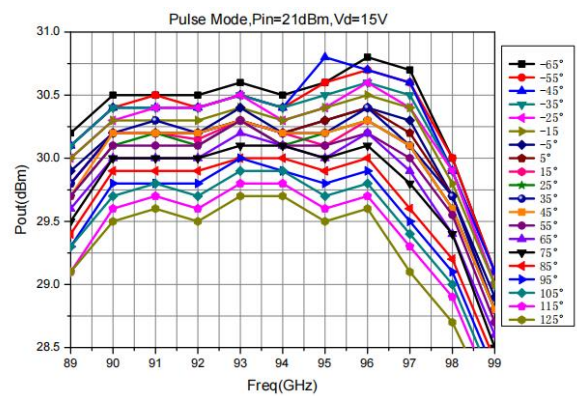

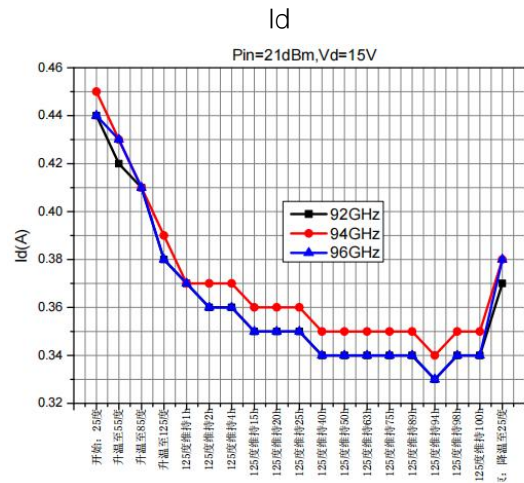
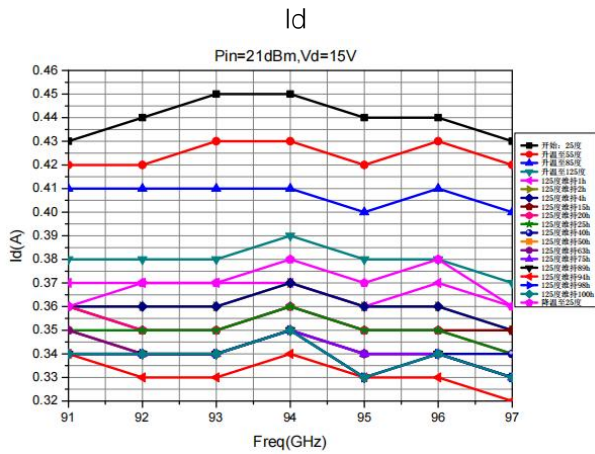
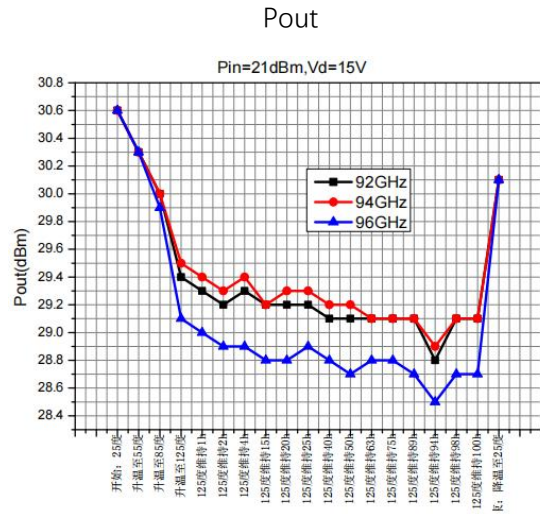
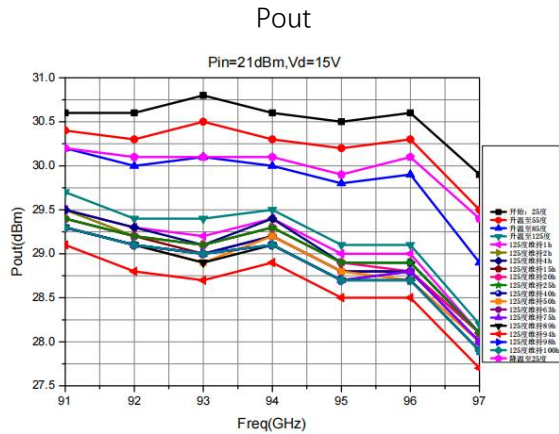



Absolute Max Ratings (TA=25°C)

Symbol	Parameter	Value	Remark
Vd	Drain Voltage	20V	
Id	Drain Current	0.55A	
Vg	Gage Voltage	-4V	
Ig	Gate Current	10mA	
Pd	DC Power	10W	
Pin	Input Power	25dBm	
Tch	Channel Temperature	200°C	
Tm	Mounting Temperature	290°C	1 min, N2 Protection
Tstg	Storage Temperature	-55~150°C	

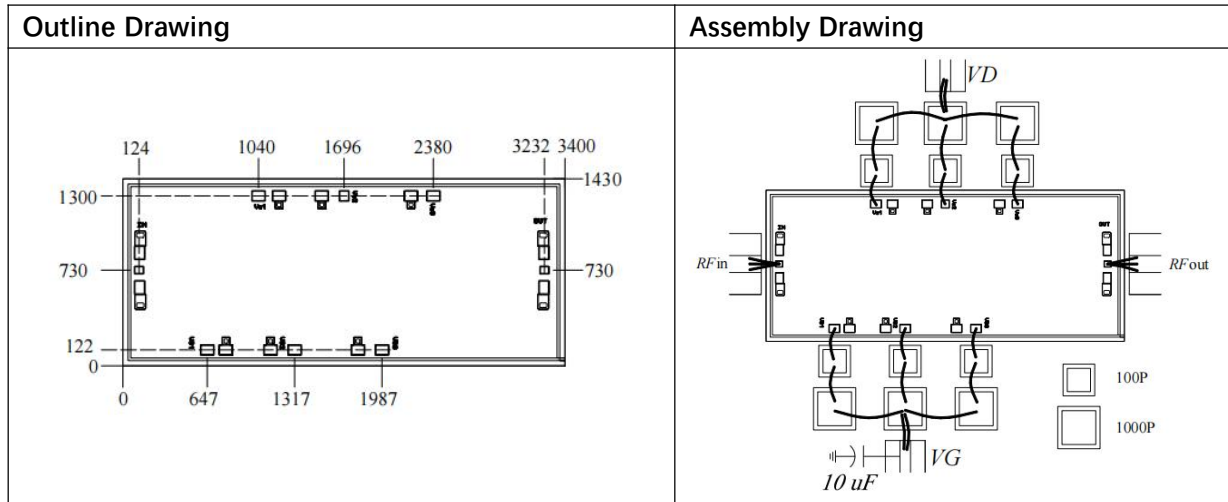
Exceeding any one or combination of these limits may cause permanent damage.

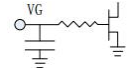
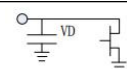

Pads Definition

Pad	Description	Equivalent Circuit
RFin	RF Signal input, connect to 50ohm system, no need block capacitor.	
RFout	RF Signal output, connect to 50ohm system, no need block capacitor.	
VG1、VG2、VG3	Amp gate bias, external 100pF, 1000pF capacitor is needed	
VD1、VD2、VD3	Amp drain bias, external 100pF, 1000pF capacitor is needed	
GND	Bottom must connect to RF and DC ground	