

Performance

- Frequency: 32~38GHz
- Typical Signal Gain: 24dB
- Typical Pout: 37.5dBm@20V
- Typical PAE: 33%
- Bias: 20V, -2V
- Technology: 0.15um HEMT
- Size: 3.2*1.4mm*0.05mm

Function Diagram

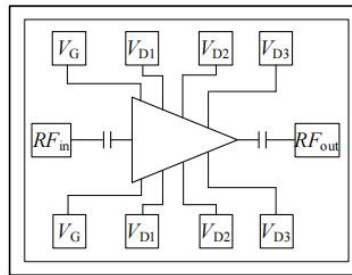

Electrical Specifications (TA=25°C, Vd=20V, Idq=0.25A, F:32~38GHz)

Symbol	Parameter	Min	Typical	Max	Unit
G	Small Signal Gain	-	24	-	dB
Gp	Power Gain	-	17.5	-	dB
Pout	Saturated Power	-	37.5	-	dBm
PAE	Power Added Efficiency	-	33	-	%
Rth	Thermal Resistance	-	4.5	-	°C/W

Test Curves

Small Signal Gain@ Different Temp

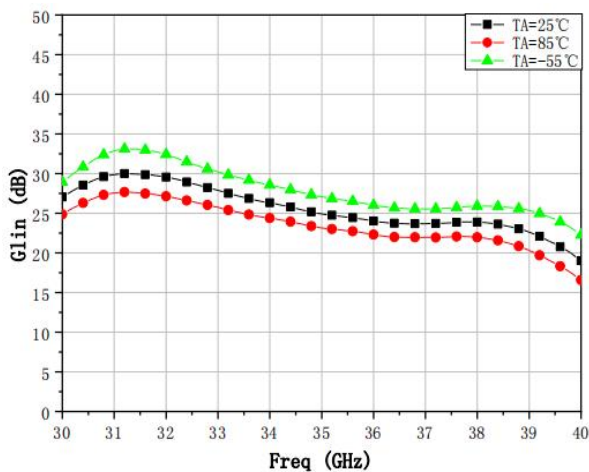

VSWRin@ Different Temp

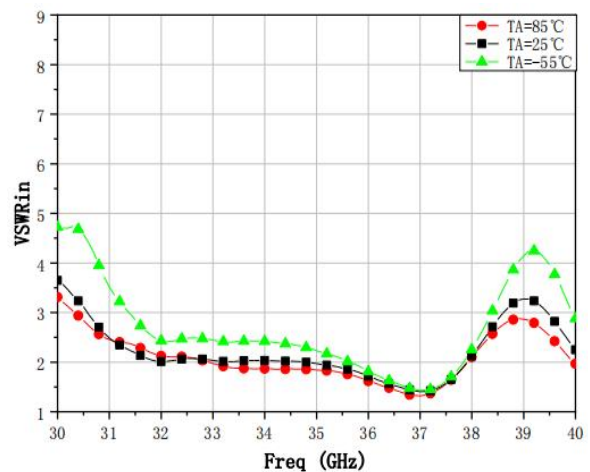

Pout@ Different Temp

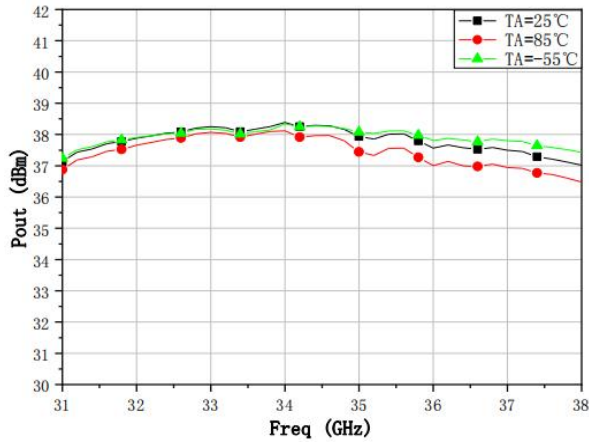

Id@ Different Temp

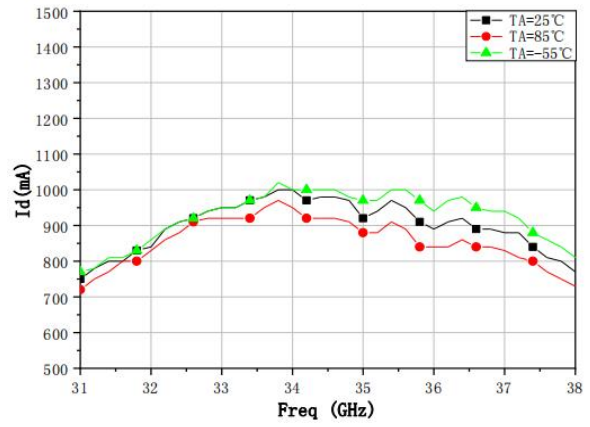

PAE@ Different Temp

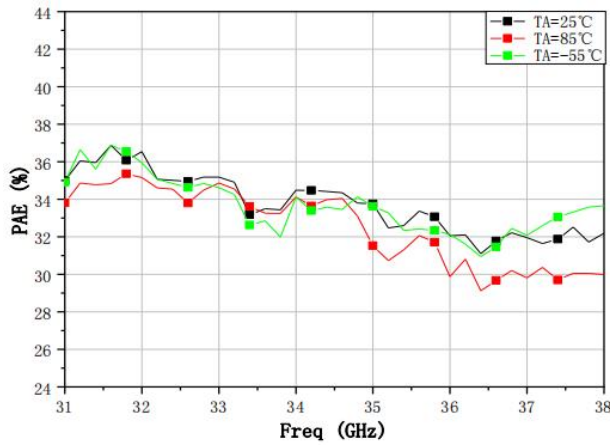

Ig@ Different Temp

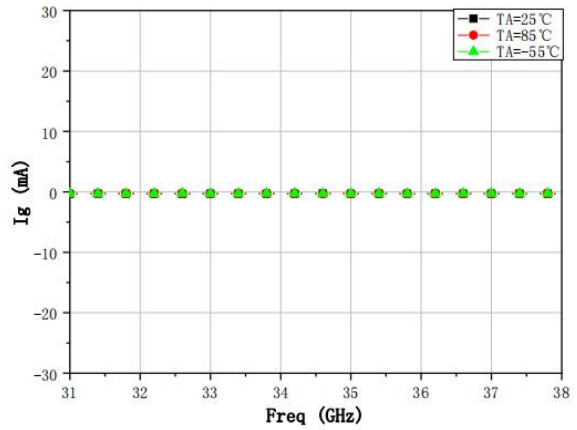



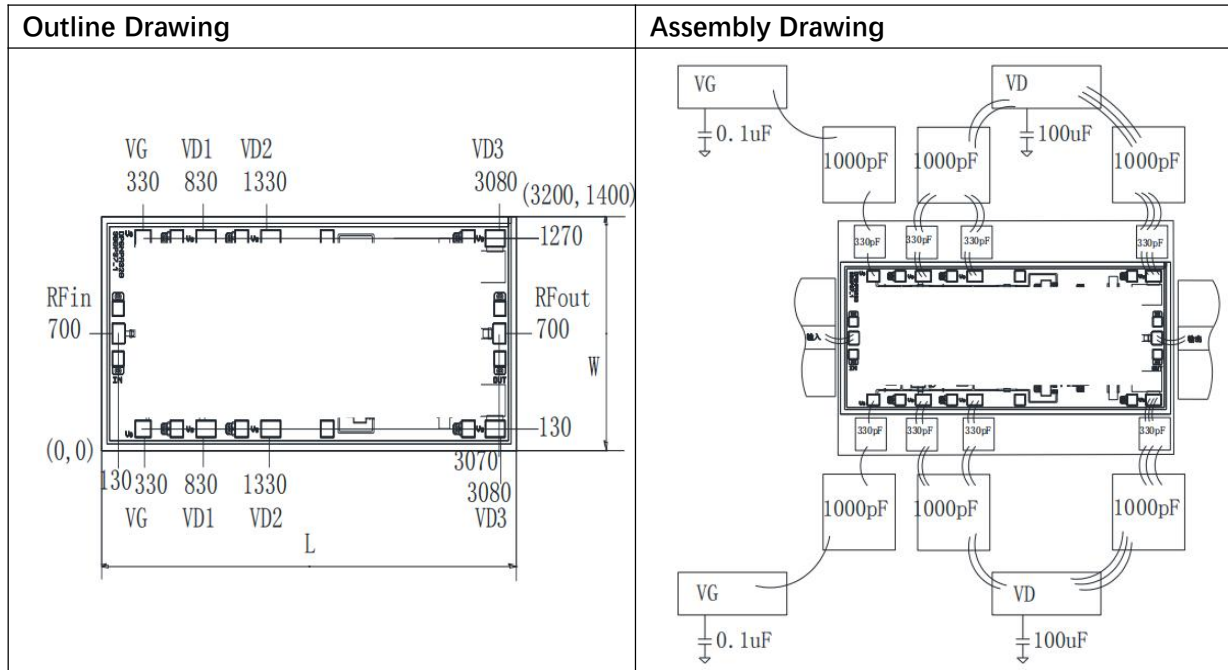

Absolute Max Ratings (TA=25°C)

Symbol	Parameter	Value	Remark
Vd	Drain Voltage	28V	
Id	Drain Current	1.7A	
Pd	DC Power	46W	
Pin	Input Power	26dBm	
Tch	Channel Temperature	175°C	
Tm	Mounting Temperature	310°C	1 min, N2 Protection
Tstg	Storage Temperature	-65~150°C	

Exceeding any one or combination of these limits may cause permanent damage.

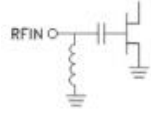

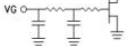
Pads Definition

Pad	Description	Equivalent Circuit
RFIn	RF Signal input, connect to 50ohm system, no need block capacitor.	
RFout	RF Signal output, connect to 50ohm system, no need block capacitor.	
VG	Amp gate bias, external 1000pF capacitor is needed	
VD1、VD2	Amp drain bias, external 1000pF capacitor is needed	
GND	Bottom must connect to RF and DC ground	