

Performance

- Frequency: 3.7~4.2GHz
- Typical Signal Gain: 27dB
- Typical Pout: 39dBm@28V
- Typical PAE: 55%
- Bias: 28V, -2.6V, 105mA (Typ.)
- Mode: CW
- Technology: 0.15um HEMT
- Size: 1.41*2.36mm*0.08mm

Function Diagram

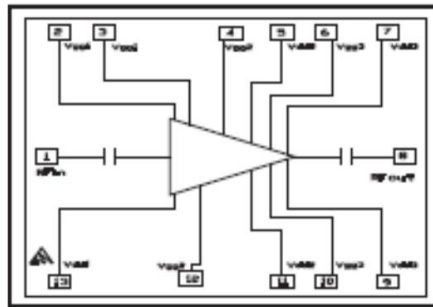

Electrical Specifications (TA=25°C, CW)

Symbol	Parameter	Min	Typical	Max	Unit
G	Small Signal Gain	-	27	-	dB
Gp	Power Gain	-	21	-	dB
Pout	Saturated Power	-	39	-	dBm
PAE	Power Added Efficiency	-	55	-	%
R	Thermal Resistance	-	-	-	°C/W

Test Curves

Small Signal Gain@ Different Temp

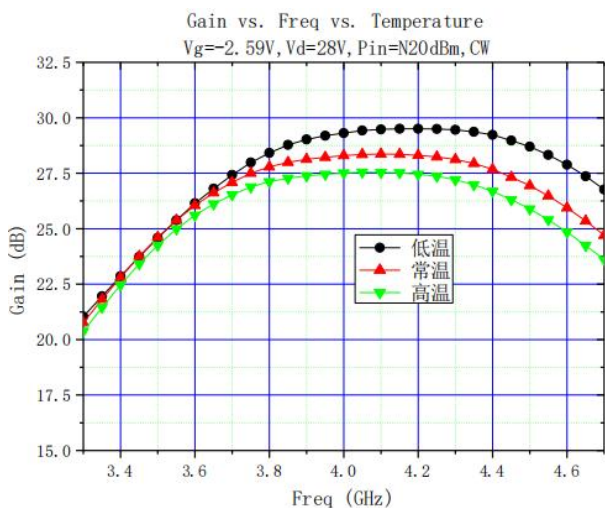

VSWRin@ Different Temp

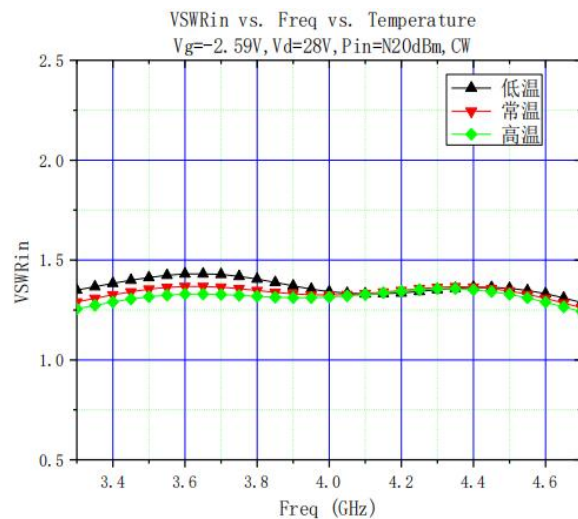

Small Signal Gain@ Different Vd

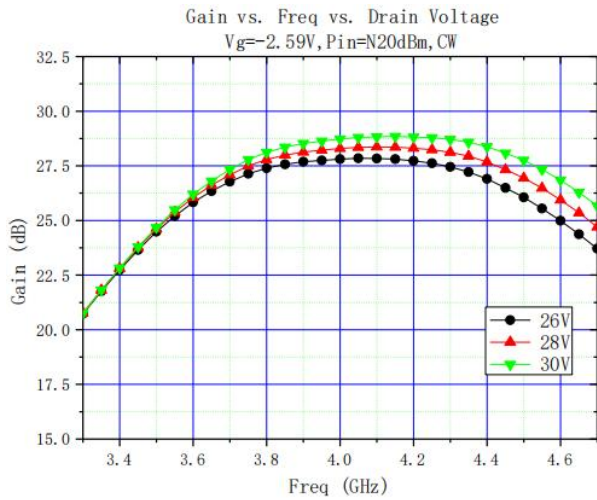

VSWRin@ Different Vd

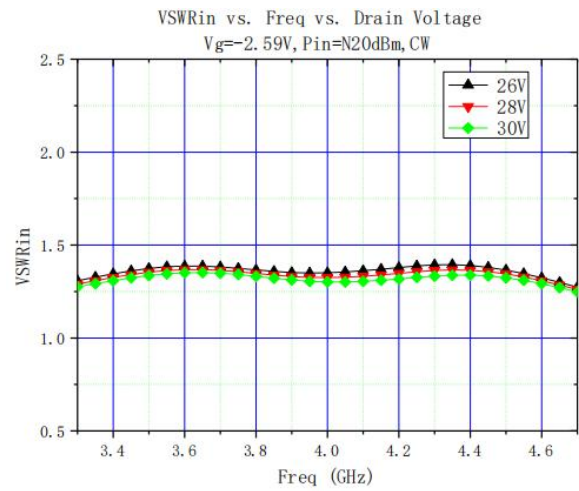

Pout@ Different Temp

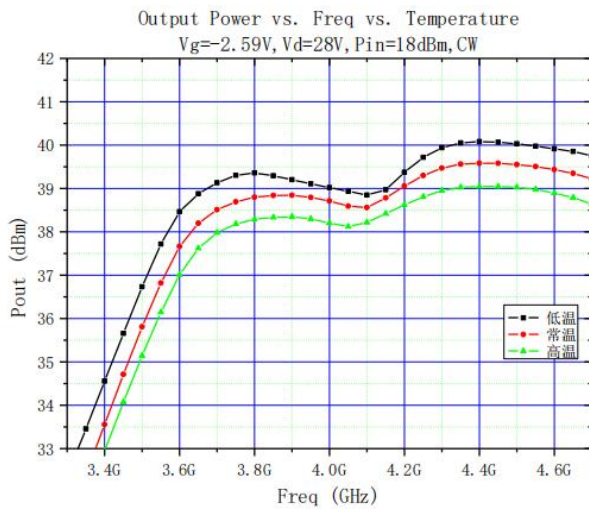

PAE@ Different Temp

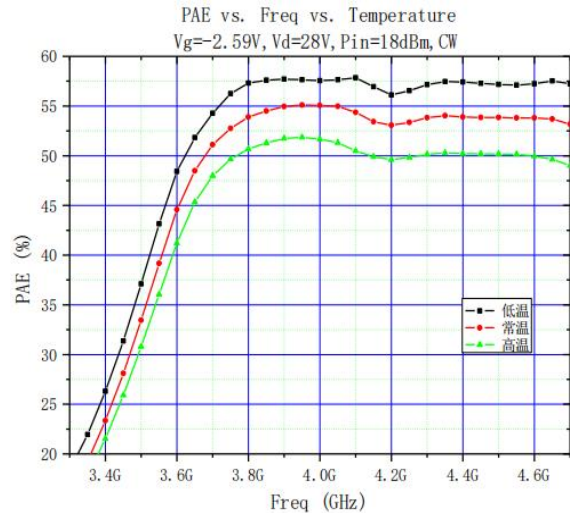

Pout@ Different Vd

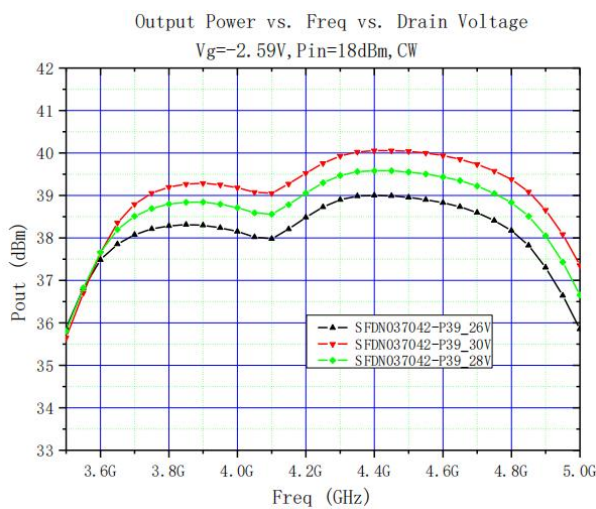

PAE@ Different Vd

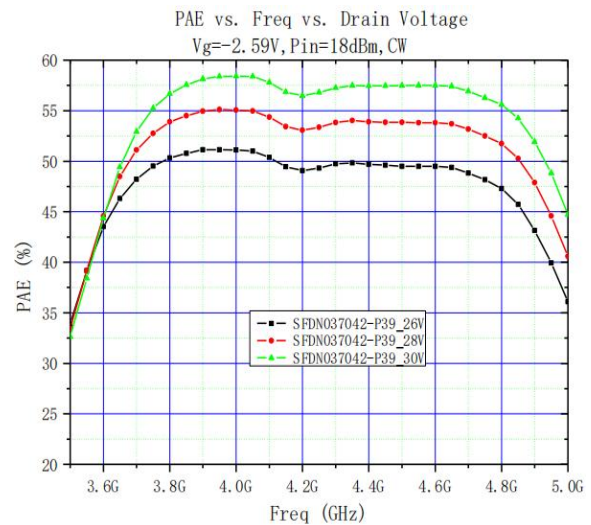

Pout@ Different Pin

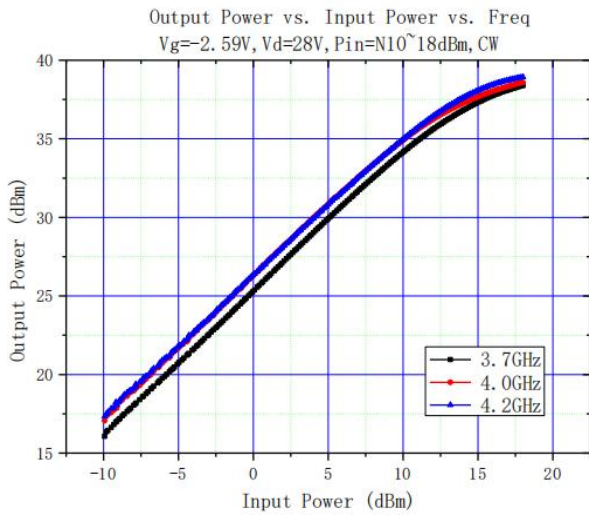

PAE@ Different Pin

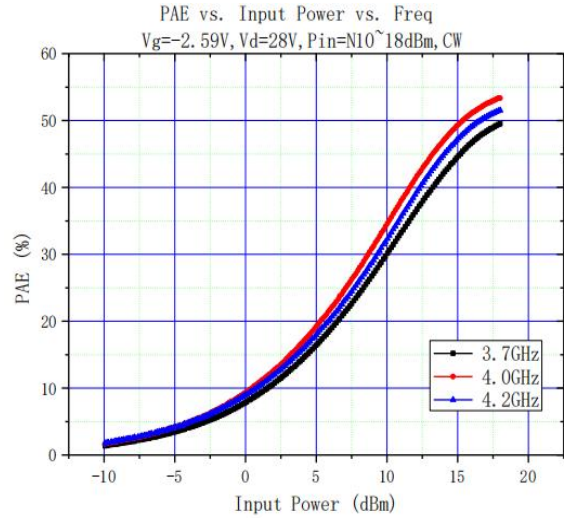

Id@ Different Pin

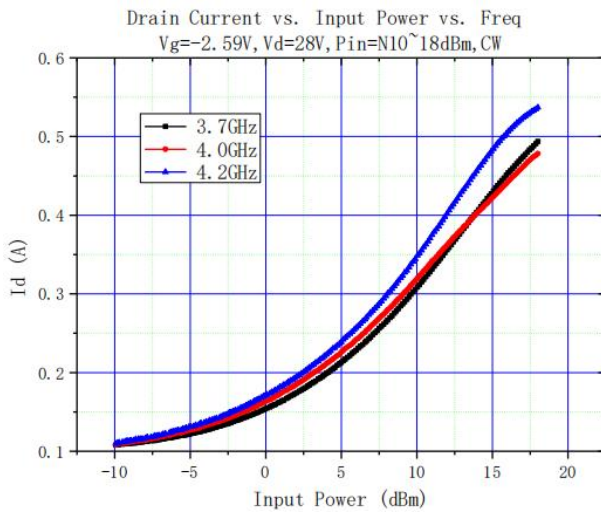

Ig@ Different Pin

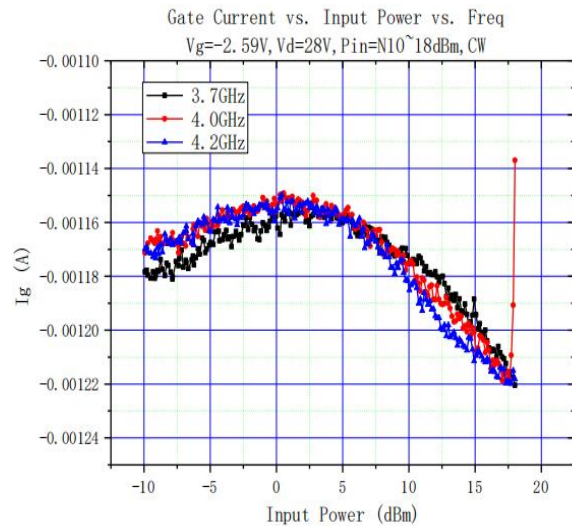

Id@ Different Vd

不同漏压下漏电流曲线

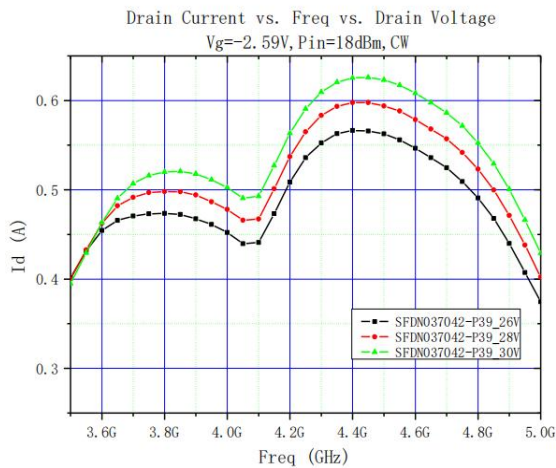

Ig@ Different Vd

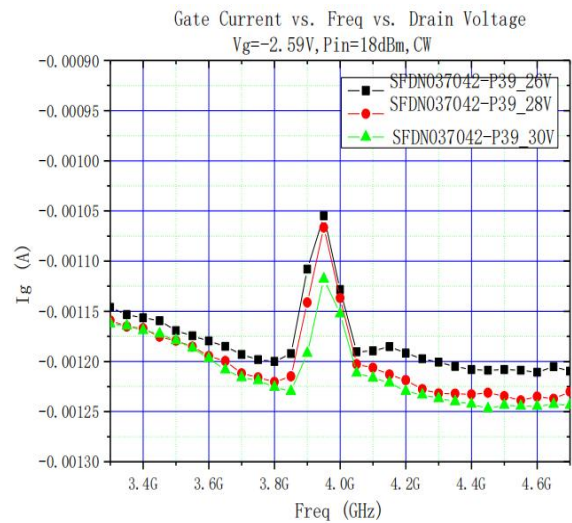

IM3

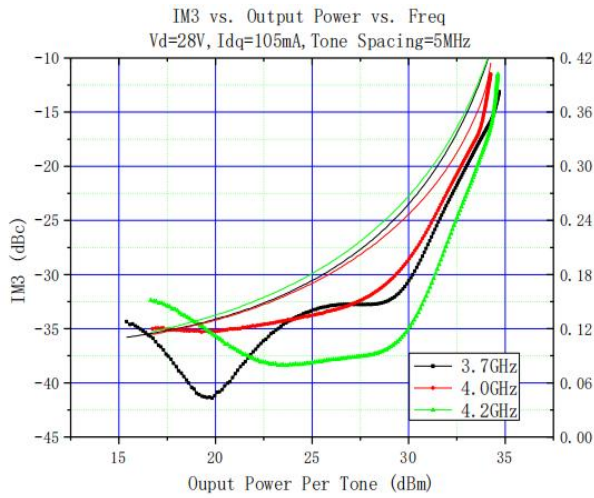

Absolute Max Ratings (TA=25°C)

Symbol	Parameter	Value	Remark
Vd	Drain Voltage	32V	
Id	Drain Current	5A	
Vg	Gate Voltage	-10V	
Ig	Gate Current	10mA	
Pd	DC Power	110W	
Pin	Input Power	28dBm	
Tch	Channel Temperature	175°C	
Tm	Mounting Temperature	310°C	1 min, N2 Protection
Tstg	Storage Temperature	-55~175°C	

Exceeding any one or combination of these limits may cause permanent damage.

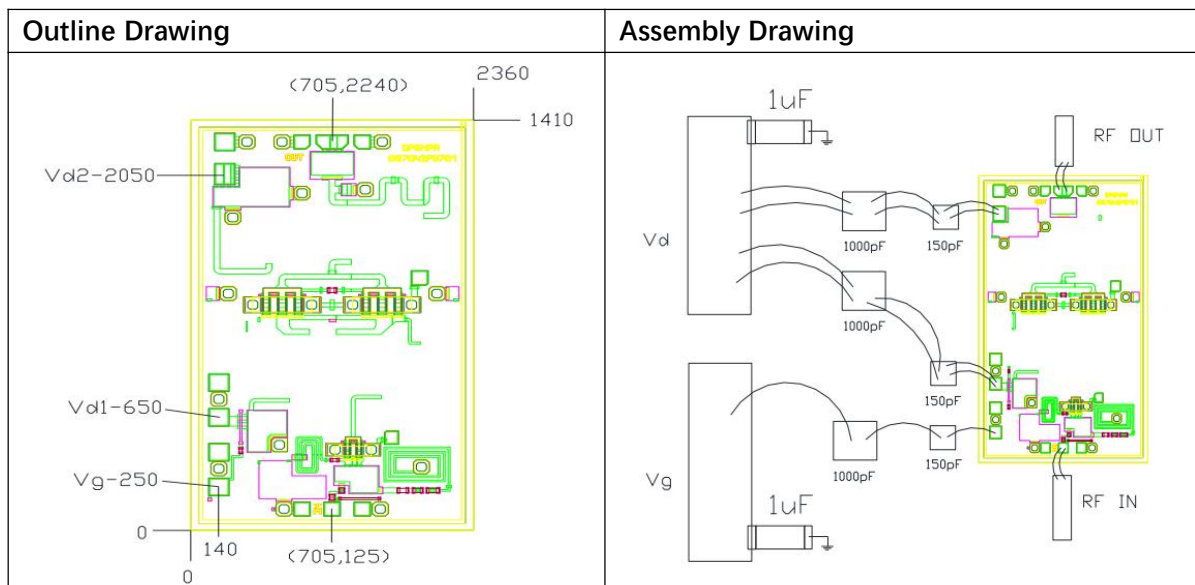

Pads Definition

Pad	Description
RFin	RF Signal input, connect to 50ohm system, no need block capacitor.
RFout	RF Signal output, connect to 50ohm system, no need block capacitor.
VG、VG1	Amp gate bias, external 1000pF capacitor is needed
VD、VD1、VD2、VD3、VD4	Amp drain bias, external 150pF capacitor is needed
GND	Bottom must connect to RF and DC ground