

Performance

- Frequency: 17.5~20GHz
- Typical Signal Gain: 30dB
- Typical Pout: 40.5dBm
- Typical PAE: 44%
- Static Operating Current: 0.9A
- Dynamic Operating Current: 1.25A
- Bias: -2.2V, 20V/22V
- Technology: GaN HEMT
- Size: 4.2*1.8mm*0.05mm

Function Diagram

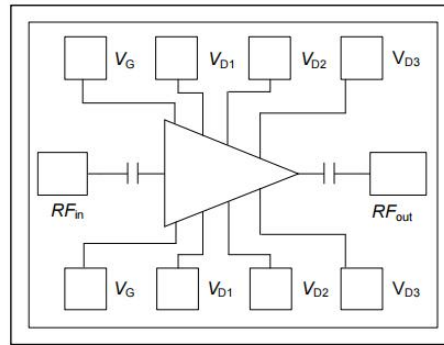

Electrical Specifications (T_A=25°C, V_d=20V, V_g=-2.2V, F: 17.5~20GHz)

Symbol	Parameter	Min	Typical	Max	Unit
G	Small Signal Gain	-	30	-	dB
G _p	Power Gain	-	18.5	-	dB
P _{out}	Saturated Power	-	40.5	-	dBm
I _d	Dynamic Current	-	1.25	-	A
R _{th}	Thermal Resistance	-	3.5	-	°C/W

Test Curves

VSWR_{in}@ Different Temp

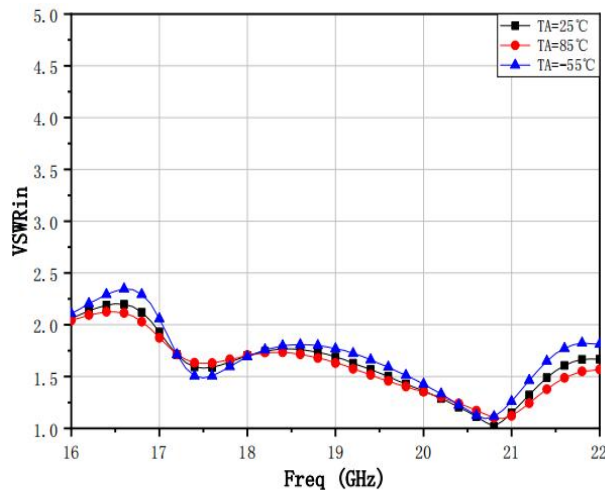

Small Signal Gain@ Different Temp

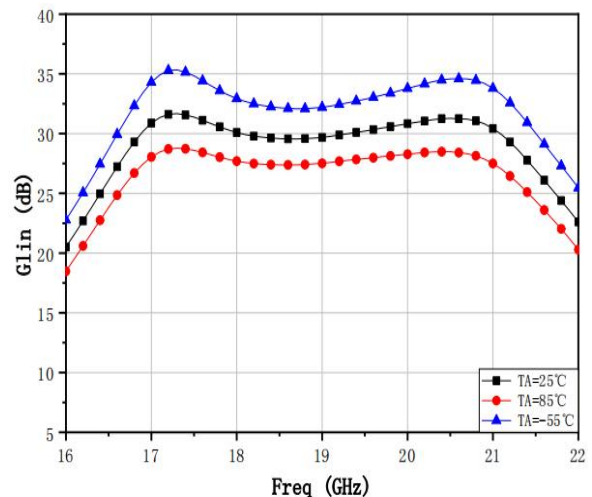

Pout@ Different Temp

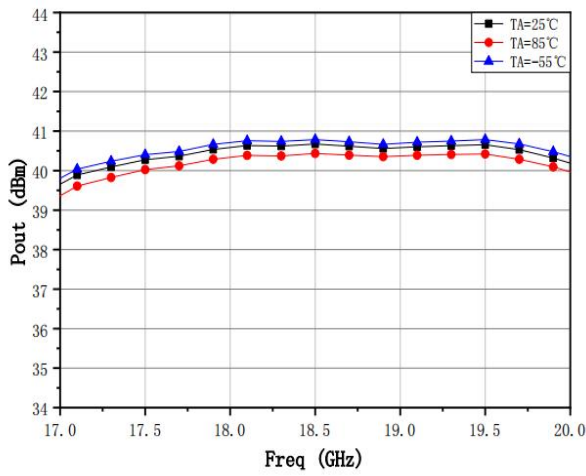

PAE@ Different Temp

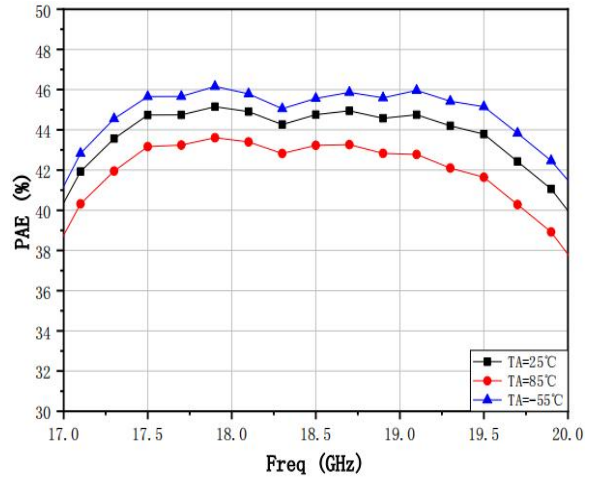

Id@ Different Temp

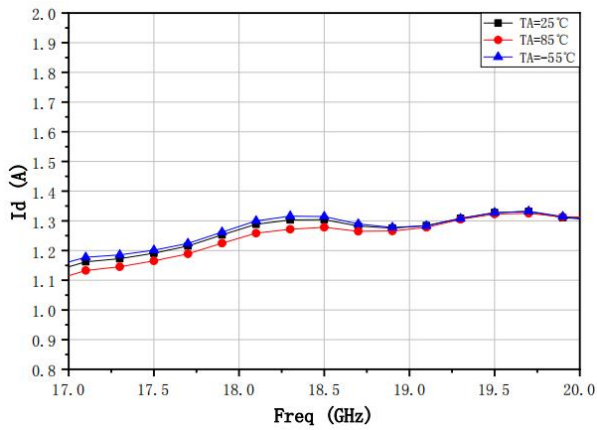

Ig@ Different Temp

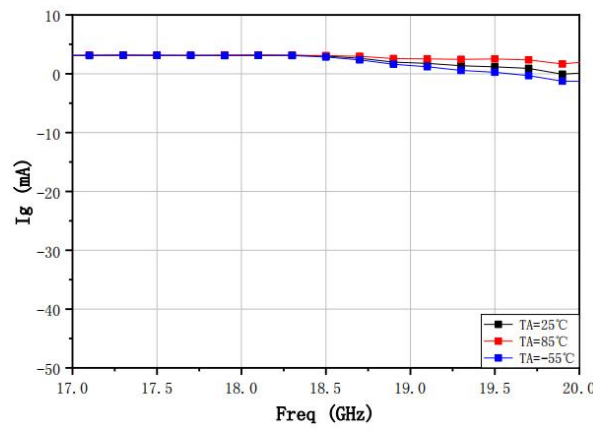

Pout@ Different Pin

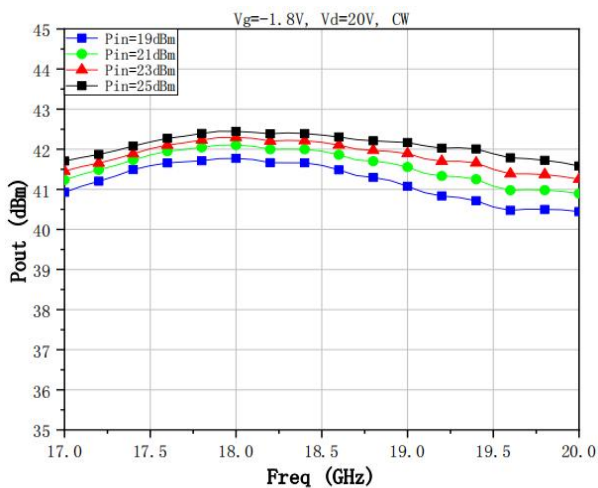

PAE@ Different Pin

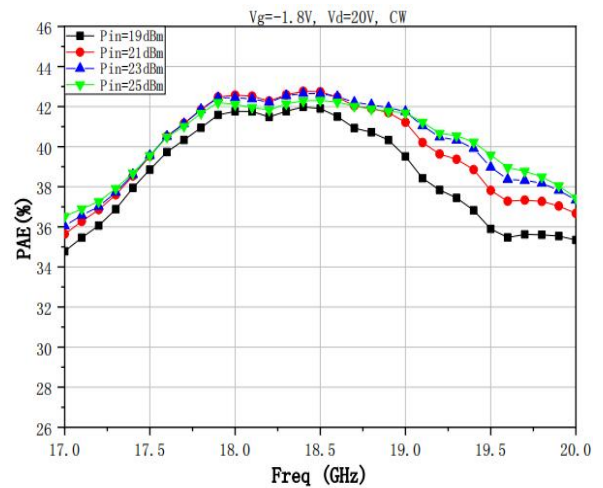

IMD3 VS pout/per tone

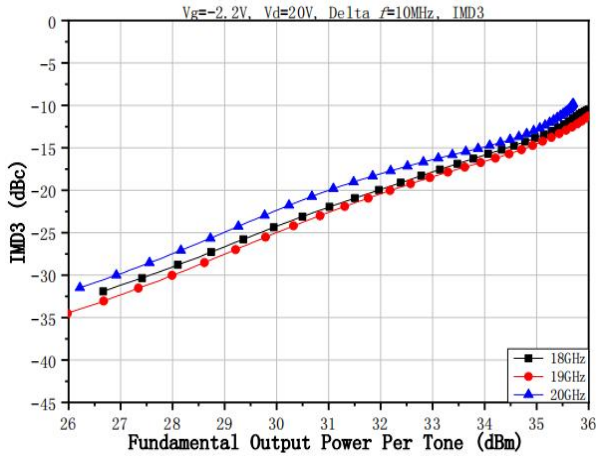

IMD3 VS pout/per tone

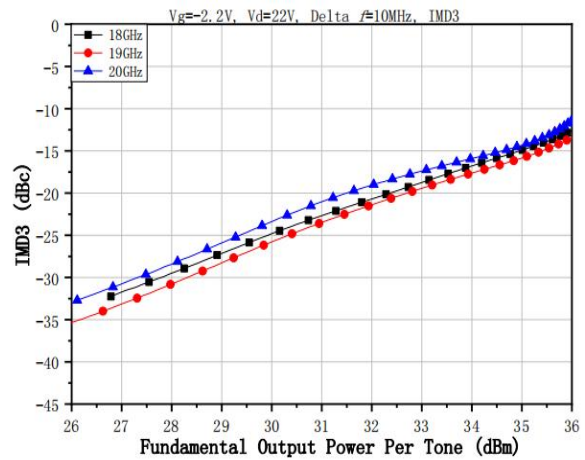

Absolute Max Ratings (TA=25°C)

Symbol	Parameter	Value	Remark
Vd	Drain Voltage	28V	
Id	Drain Current	2.5A	
Pd	DC Power	70W	
Pin	Input Power	27dBm	
Tch	Channel Temperature	175°C	
Tm	Mounting Temperature	290°C	30 s, N2 Protection
Tstg	Storage Temperature	-65~150°C	

Exceeding any one or combination of these limits may cause permanent damage.

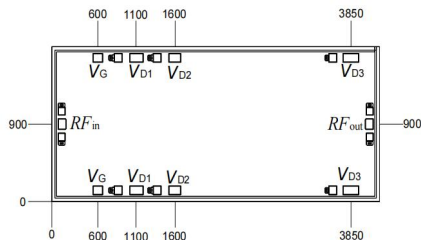

Outline Drawing

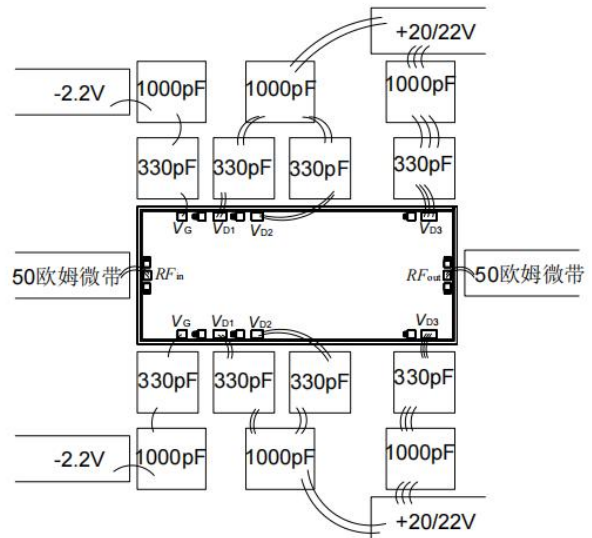

Assembly Drawing

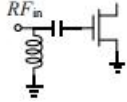
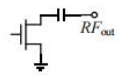
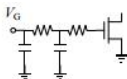

Pads Definition

Pad	Description	Equivalent Circuit
RFin	RF Signal input, connect to 50ohm system, block capacitor is needed if there's external DC applied on this pad.	
RFout	RF Signal output, connect to 50ohm system, no need block capacitor.	
VG	Amp gate bias, external 330pF, 1000pF capacitor is needed	
VD1、VD2、VD3	Amp drain bias, external 330pF, 1000pF capacitor is needed	
GND	Bottom must connect to RF and DC ground	